

Kifix[®]
GRUPO

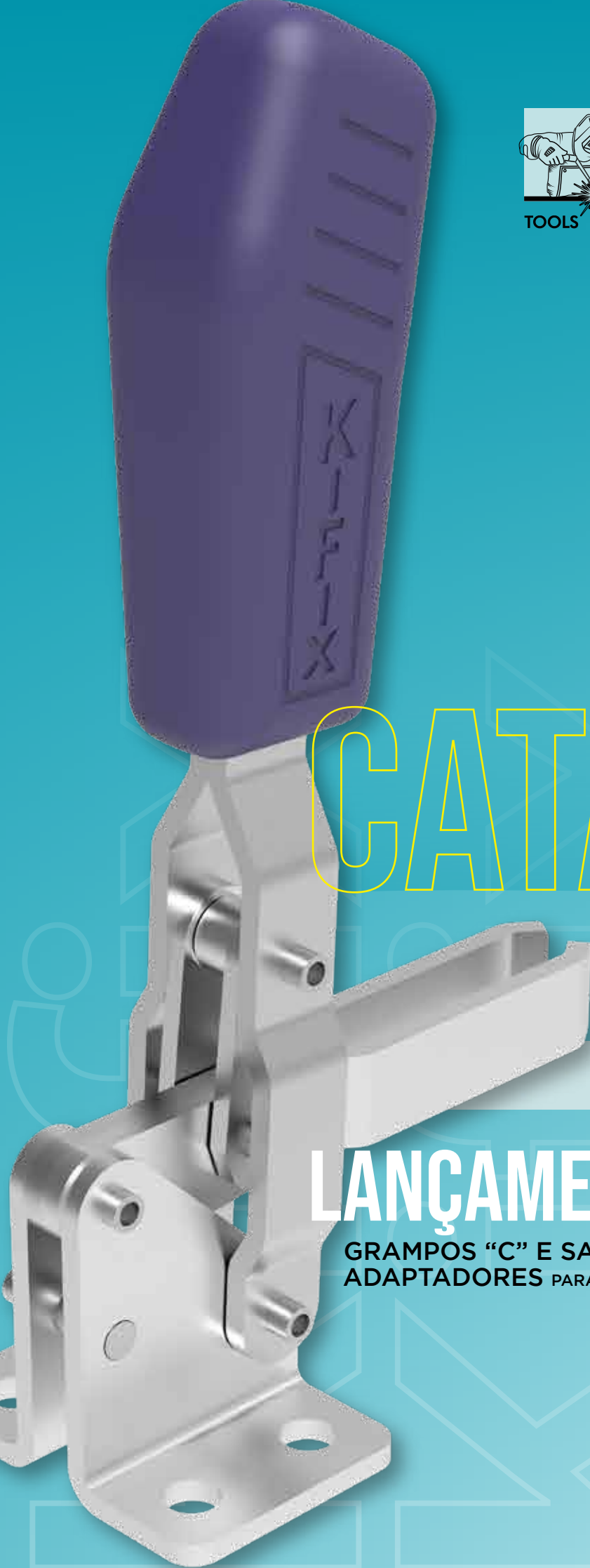

KIFIX CATÁLOGO 23124

LANÇAMENTOS

GRAMPOS "C" E SARGENTOS
ADAPTADORES PARA MESAS DE SOLDA

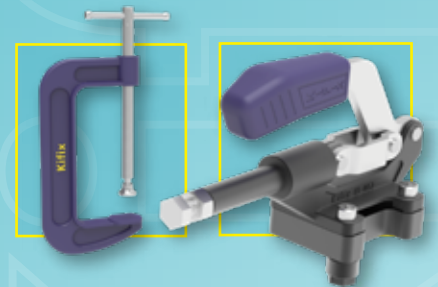

DESDE 2004

A KIFIX

Sediada em Caxias do Sul, no estado do Rio Grande do Sul, nossa empresa se dedica à fabricação de grampos de fixação rápida desde 2004. Oferecemos mais de 700 produtos de alta qualidade, atendendo a diversos setores industriais, como ferramentarias, serralherias, indústrias metalúrgicas, moveleiras, químicas, cosméticas, alimentícias, automobilísticas, autopeças, entre outros.

Em 2022, ampliamos nossas operações ao introduzir o serviço de corte a laser, aproveitando a oportunidade proporcionada pela aquisição de uma máquina com tecnologia avançada. Inicialmente centrado no corte de peças para nossos grampos, percebemos o potencial desse serviço e, em 2022, estabelecemos um setor dedicado para conduzir nossa segunda unidade de negócio.

No ano seguinte, em 2023, evoluímos para um grupo empresarial ao incorporar mais uma unidade de negócio. Esta expansão foi concretizada por meio da distribuição da Siegmund no Brasil, uma empresa alemã de renome mundial na fabricação de mesas e acessórios para solda. Como distribuidores oficiais no Brasil, através da Kifix Tools, consolidamos nossa presença no mercado ao oferecer produtos de alta qualidade, agilidade e soluções especializadas para o seu processo.



****As imagens desse catálogo são ilustrativas e servem para identificar o produto.
A Kifix se reserva o direito de alterar sem qualquer aviso prévio.**

pag 06 Grampos verticais

KF-718
KF-631
KF 010 / KF-012 / KF-017 / KF-018 / KF-016 / KF-011 / KF-111
KF-017 T
KF-010F / KF-012F / KF-019 / KF-211 / KF-311 / KF-411
KF-615 / KF-616 / KF-641 / KF-066 / KF-845 / KF-875
KF-017 DS A / KF-011 DS A / KF-011 DS A JD / KF-111 DS A
KF-211 DS A / KF-311 DS A / KF-411 DS A
KF-MP / KF-JD
KF-725 / KF-825
KFU

pag 17 Grampos horizontais

KF-105 / KF-106 / KF-107 / KF-152 / KF-732 / KF-511 / KF-512 / KF-521 / KF-522 / KF-532 / KF-534
KF-106 F / KF-107 F / KF-152 F / KF-312 F / KF-522 F / KF-531 F
KF-531 / KF-541 / KF-312 / KF-712 / KF-523 / KF-722 / KF-533
KF-102 / KF-101 / KF-103 / KF-104 / KF-515

pag 24 Grampos horizontais reforçados

KF-524 D / KF-525 D / KF-527 D / KF-528 D

pag 25 Grampos tensores

KF-310 / KF-314 / KF-326 / KF-320
KF-233 / KF-643 / KF-743 / KF-133 / KF-843 / KF-943 / KF-143
KF-033 / KF-353 / KF-153 / KF-453 / KF-553
KF-063 / KF-163 / KF-263 / KF-423 / KF-433 / KF-443 / TKF-473
KF-330 / KF-350 / KF-340 / KF-375 / KF-385
KFC3 / KFC4 / KFC5

pag 31 Grampos tensores com cinta

KF-233 CT / KF-743 CT / KF-843 CT

pag 32 Grampos torpedos

KF-305 / KF-405 / KF-505 / KF-605 / KF-067
KF-061 / KF-057 / KF-051 / KF-054 / KF-053 / KF-052 / KF-056

pag 34 Grampos torpedos com alça

KF-025 AL / KF-057 AL / KF-054 AL / KF-053 AL / KF-052 / KF-056

pag 35 Grampo torpedo com giro

KF-007 G

pag 36 Grampos torpedos frontais

KF-005 / KF-006 / KF-007 / KF-009 / KF-015 / KF-025 / KF-035
BASES "L" PARA TORPEDOS

pag 37 Grampo torpedo com haste quadrada

KFKT-012

PRODUTOS

pag 38 Grampos de fixação dupla

KF-686 D / KF-687 D / KF-686 H

pag 39 Fusos rápidos

KFRL / KFRF

pag 39 Manípulos

KFM-6 / KFM-8 / KFM-10 / KFM12 / KFM-16

pag 40 Grampos sargentos

KFS-150 / KFS-300

pag 40 Grampos compressores

KF-035 34 / KF-035 60 / KF-035 3660 / KF-035 100

pag 41 Grampos pneumáticos

KF-012 P / KF-017 P / KF-011 P / KF-111 P
KF-057 P / KF-052 P / KF-066 P
KF-019 P / KF-311 P / KF-411 P
KF-718 P

pag 44 Grampos pneumáticos pesados

KFP-L40 / KFP-L63

pag 45 Dobradiças e trincos

KFD-14 / KFD 19
KFT-10 / KFT-14

pag 45 Alicates

KFA-300
KF-325 / KFA-25 / KFA-35 / KFA-45 / KFA-70 / KFA-90 / KFA-100 / KFA-150

pag 47 Alça

KF-AL

pag 47 Ponteiras

PC / PF
PP / PS / PSB / PA / ARP / ARB / PB / BRP / BRB / BAP / PBC / BRPC
PSD / PBD

pag 50 Bases para mesas de solda

MS BE / MS FU / MS BV / MS BH / KFA MS / KFA L MS

pag 54 Grampos sangentos

KFSG / KFSR / KFSC

MECANISMO

O sistema de fixação rápida recebeu denominações variadas através do tempo, por exemplo: presilha, prensa manual, fixador, grampo (CLAMP USA).

Esse mecanismo consiste em uma articulação de três pontos conhecida como “ação de joelho ou cotovelo”, a qual proporciona um travamento mecânico (veja na figura abaixo) que gera uma força de retenção contrária ao esforço aplicado e que só se destrava se acionado propositalmente.

Para evitar o destravamento aleatório, disponibilizamos também grampos de fixação rápida com trava de segurança.

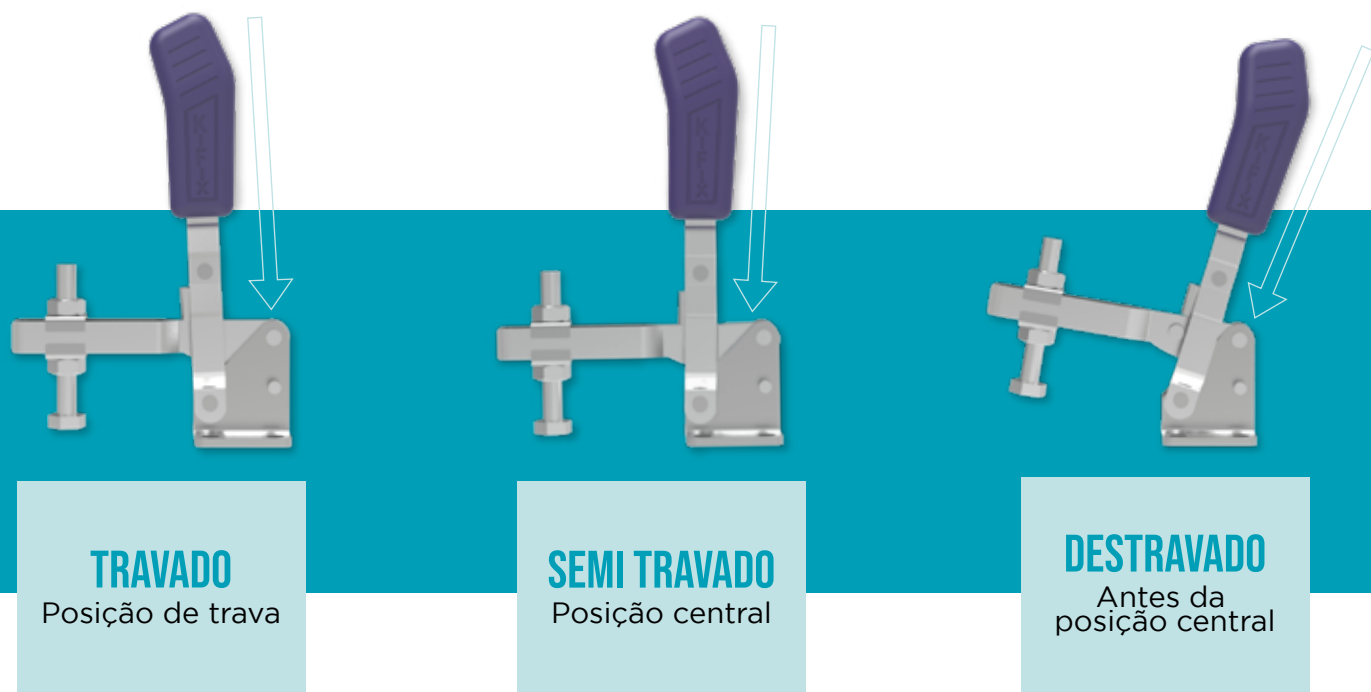

FORÇA DE RETENÇÃO

A força de retenção é proporcional a distância do ponto de giro (A) ao ponto de fixação da ponteira (B/C).

Quanto maior a distância entre o ponto A e o ponto de fixação da ponteira, menor será a força de retenção do fixador.

A força de retenção é proporcional a distância do ponto de giro (A) ao ponto de fixação da ponteira (B).

Distancia AC: 135mm (especificado no catálogo) = 680 Kgf.

Distancia AB: 90mm ($680 \times AC / AB = 680 \times 135 / 90 = 1.020$ kgf).

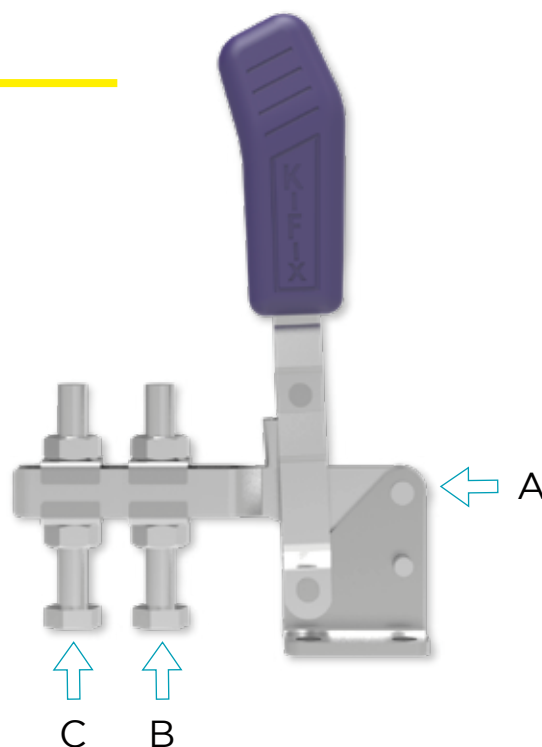

CORES DOS CABOS

Possuímos opções de cores para os cabos dos grampos, azul (cor padrão) preto, vermelho, laranja e verde. E para os cabos modelo alça possuímos as cores azul (padrão), preto e vermelho. Produzido em PVC.



Azul (padrão)



Preto



Vermelho



Laranja



Verde



Preto



Vermelho



Azul (padrão)

PROJETOS ESPECIAIS

Trabalhamos com o desenvolvimento de novos projetos ou adaptação de produtos existentes, conforme a necessidade do cliente, podendo elaborar algo específico para cada negócio.

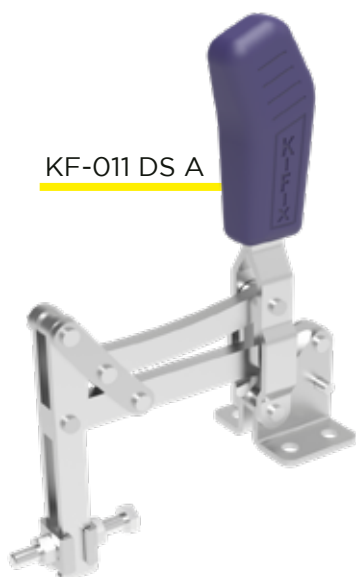

KF-011 DS A



Adaptação

KF-011 DS A JD

GRAMPOS VERTICAIS

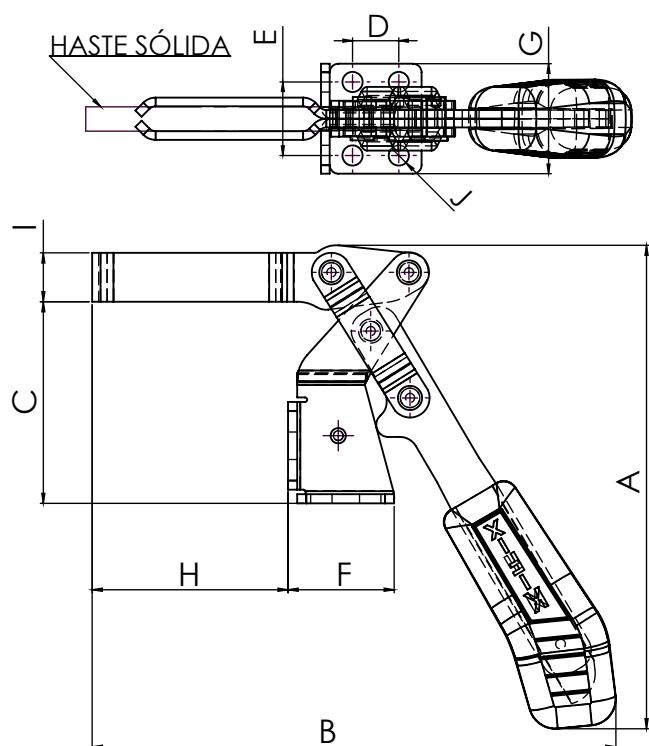
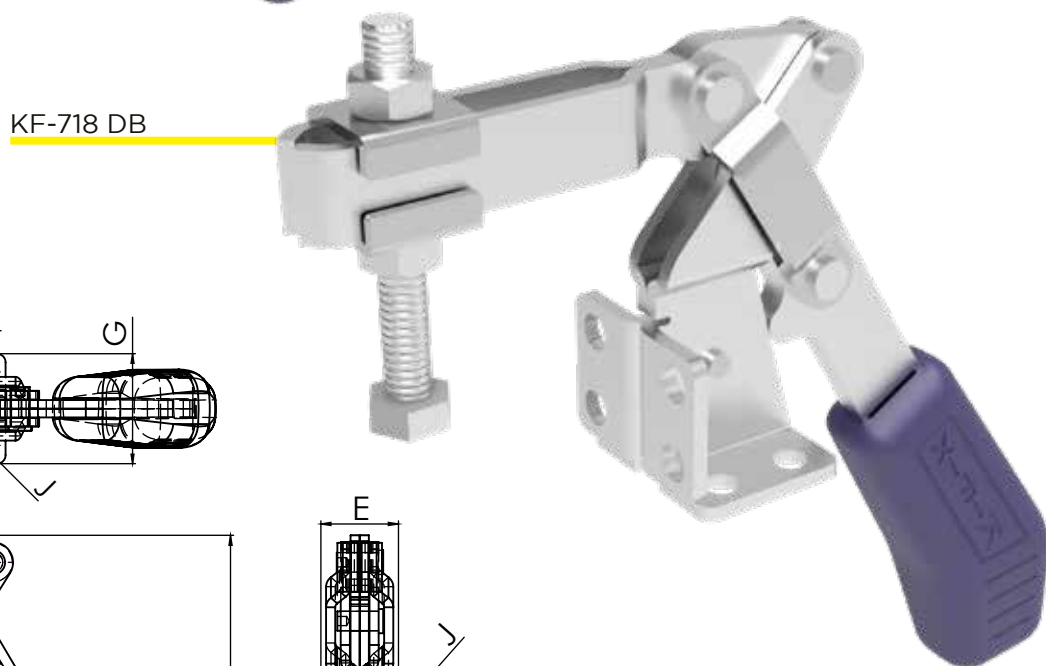
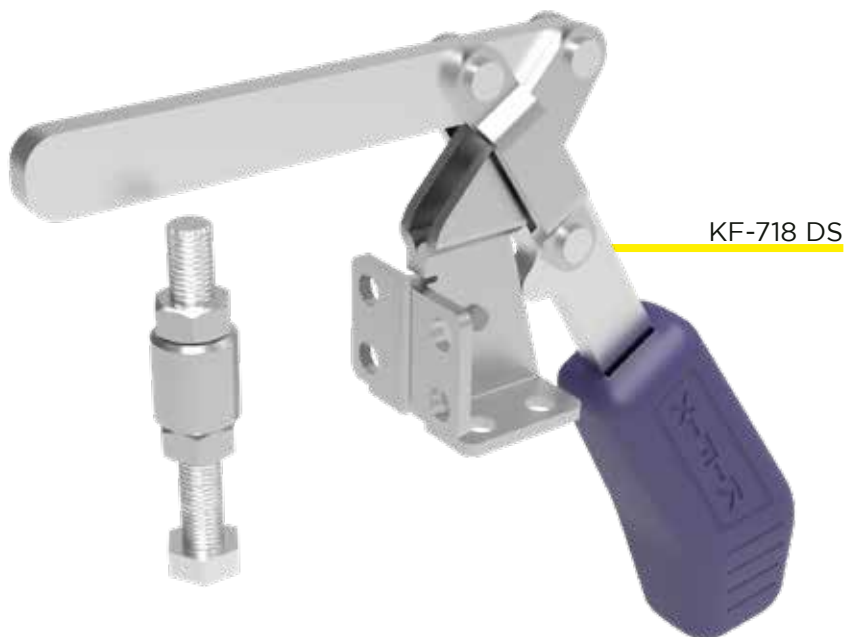

BASES
 D - Dobrada
 R - Reta

HASTES
 B - Bifurcada
 S - Sólida

REFERÊNCIA	FORÇA DE RETENÇÃO KGF	A	B	C	D	E	F	G	H	I	J	PONTEIRA	ÂNGULO DE ABERTURA	PESO KG
KF-718 DB	170	158,3	171,5	66	16	25,4	35	38	64	16	7	M8	185	0,5
KF-718 DS	170	170,6	198,3	66	16	25,4	35	38	82	16	7	M8	185	0,52

GRAMPOS VERTICAIS

KF-016 RS

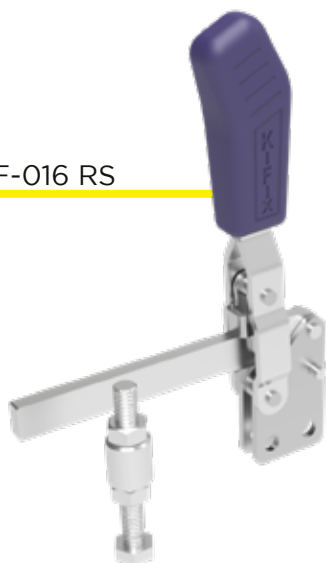

KF-018 DB TR



KF-10 DB

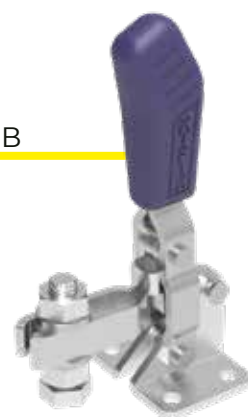

KF-017 DBL



KF-111 RBL

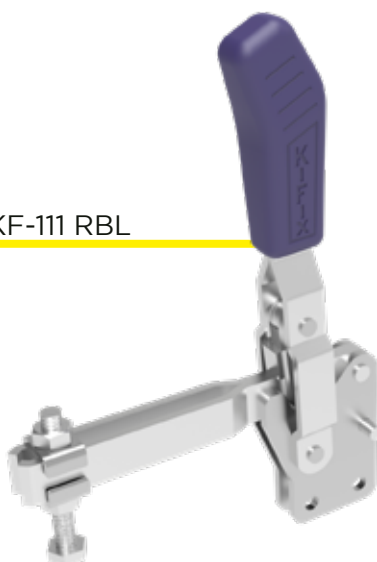

KF-18 DS

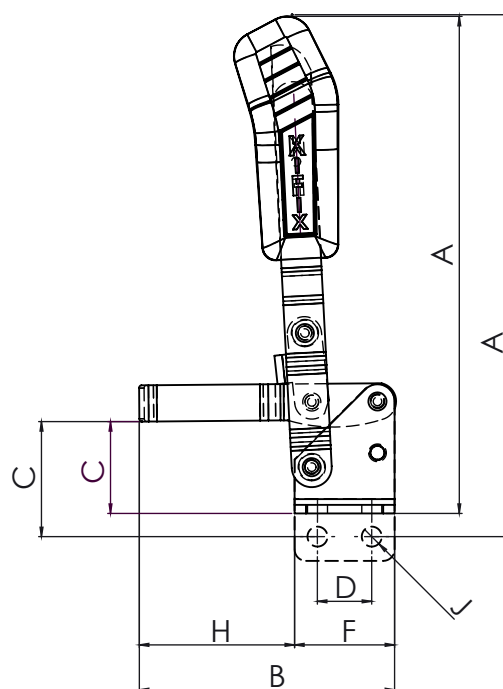
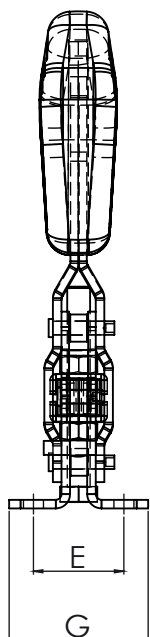
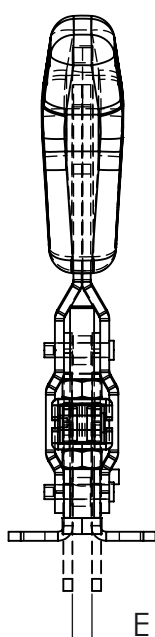
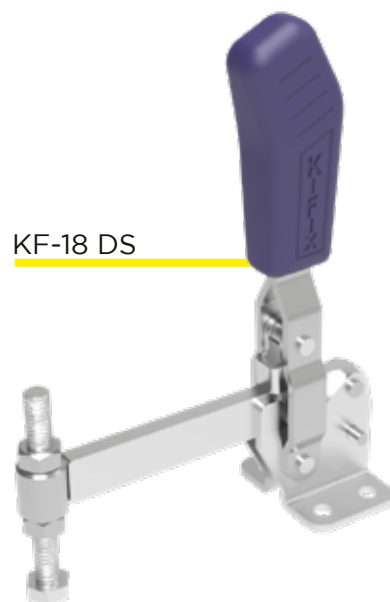

GRAMPOS VERTICAIS



KF-011 DB TR



KF-012 RB

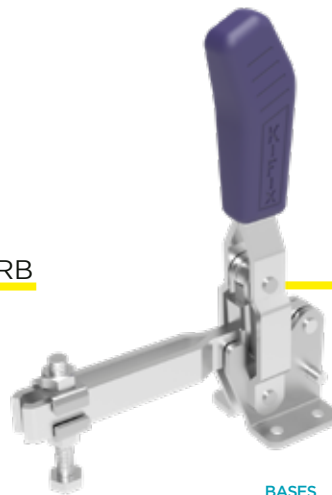

KF-111DBL

BASES
D - Dobrada
R - Retã

HASTES
B - Bifurcada
S - Sólida
L - Longa

TR - Trava

*Grampos enviados com ponteira de borracha

REFERÊNCIA	FORÇA RETENÇÃO KGf	A	B	C	D	E	F	G	H	J	PONEIRA	ÂNGULO DE ABERTURA	PESO KG
KF-010 DB*	32	86	51,3	16	16	23,9	25,4	33,3	25,9	4,3	M6	100	0,090
KF-010 RB*	32	93	51,3	23	16	4	25,4		25,9	4,3	M6	100	0,090
KF-012 DB*	90	128	70	23	12,7	27	25	39,6	45	5,6	M6	100	0,210
KF-012 DBL*	70	128	85	23	12,7	27	25	39,6	60	5,6	M6	100	0,215
KF-012 RB*	90	132	70	29	12,7	6	25		45	5,6	M6	100	0,210
KF-012 RBL*	70	132	85	29	12,7	6	25		60	5,6	M6	100	0,215
KF-017 DB	170	175	90	32	19	32	35	49	55	7,0	M8	100	0,400
KF-017 RB TR	170	175	90	32	19	32	35	49	55	7,0	M8	100	0,455
KF-017 DB TR	170	175	90	32	19	32	35	49	55	7,0	M8	100	0,400
KF-017 DBL	150	175	120	32	19	32	35	49	85	7,0	M8	100	0,410
KF-017 DBL TR	150	175	120	32	19	32	35	49	85	7,0	M8	100	0,410
KF-017 DS	200	175	120	32	19	32	35	49	85	7,0	M8	100	0,410
KF-017 RB	170	183	90	40	19	6,5	35		55	7,0	M8	100	0,400
KF-017 RBL	150	183	120	40	19	6,5	35		85	7,0	M8	100	0,410
KF-017 RS	200	183	120	40	19	6,5	35		85	7,0	M8	100	0,410
KF-018 DB	250	178	120	32	20	33,5	37	50,5	83	7,0	M8	100	0,430
KF-018 DB TR	250	178	120	32	20	33,5	37	50,5	83	7,0	M8	100	0,430
KF-018 DS	250	178	120	32	20	33,5	37	50,5	83	7,0	M8	100	0,430
KF-018 RB	250	186	120	40	20	6,5	37		83	7,0	M8	100	0,430
KF-018 RS	250	186	120	40	20	6,5	37		83	7,0	M8	100	0,430
KF-016 DB	280	175	90	31,5	19,5	32,5	35	50	55	7,5	M8	100	0,420
KF-016 DBL	260	175	137,4	31,5	19,5	32,5	35	50	102,4	7,5	M8	100	0,440
KF-016 DS	310	175	137,4	31,5	19,5	32,5	35	50	102,4	7,5	M8	100	0,440
KF-016 RB	280	183	90	39	19,5	6,7	35		55	7,5	M8	100	0,420
KF-016 RBL	260	183	137,4	39	19,5	6,7	35		102,4	7,5	M8	100	0,440
KF-016 RS	310	183	137,4	39	19,5	6,7	35		102,4	7,5	M8	100	0,440
KF-011 DB	340	211	140	41	32	44	48	60	92	8,5	M10	100	0,820
KF-011 DB TR	340	211	140	41	32	44	48	60	92	8,5	M10	100	0,820
KF-011 DBL	315	211	166	41	32	44	48	60	118	8,5	M10	100	0,850
KF-011 DBL TR	360	211	166	41	32	44	48	60	118	8,5	M10	100	0,850
KF-011 DS	340	211	166	41	32	44	48	60	118	8,5	M10	100	0,830
KF-011 RB	340	223	140	53	32	8	48		92	8,5	M10	100	0,820
KF-011 RBL	315	223	166	53	32	8	48		118	8,5	M10	100	0,850
KF-011 RS	360	223	166	53	32	8	48		118	8,5	M10	100	0,830
KF-111 DB	680	258	155	50	32	45	55	67	100	8,5	M10	100	1,400
KF-111 DB TR	680	258	155	50	32	45	55	67	100	8,5	M10	100	1,400
KF-111 DBL	650	258	200	50	32	45	55	67	145	8,5	M10	100	1,440
KF-111 DBL TR	650	258	200	50	32	45	55	67	145	8,5	M10	100	1,440
KF-111 DS	700	258	200	50	32	45	55	67	145	8,5	M10	100	1,420
KF-111 RB	680	268	155	60	32	9,5	55		100	8,5	M10	100	1,400
KF-111 RBL	650	268	200	60	32	9,5	55		145	8,5	M10	100	1,440
KF-111 RS	700	268	200	60	32	9,5	55		145	8,5	M10	100	1,420

GRAMPOS VERTICAIS



KF-631 DI TR

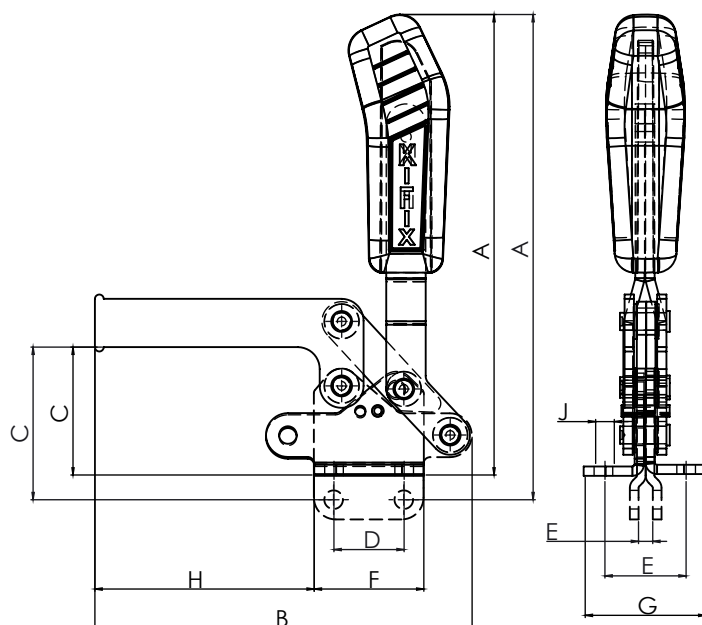

KF-631 DIL



KF-631 RL

BASES
 D - Dobrada
 R - Retá

HASTES
 B - Bifurcada
 S - Sólida
 L - Longa
 I - Invertida

TR - Trava

REFERÊNCIA	FORÇA DE RETENÇÃO KGF	A	B	C	D	E	F	G	H	J	PONTEIRA	ÂNGULO DE ABERTURA	PESO KG
KF-631 D	400	189	129	28	32	37	50	55	57	8,5	M10	85	0,92
KF-631 D TR	400	204	129	28	32	37	50	55	57	8,5	M10	85	1,05
KF-631 DI	400	189	129	56	32	37	50	55	57	8,5	M10	85	0,92
KF-631 DI TR	400	204	129	56	32	37	50	55	57	8,5	M10	85	1,05
KF-631 R	400	201	129	40	32	6,5	50		57	8,5	M10	85	0,92
KF-631 R TR	400	216	129	40	32	6,5	50		57	8,5	M10	85	1,05
KF-631 RI	400	201	129	68	32	6,5	50		57	8,5	M10	85	0,92
KF-631 RI TR	400	216	129	68	32	6,5	50		57	8,5	M10	85	1,05
KF-631 DL	300	189	172	28	32	37	50	55	100	8,5	M10	85	0,98
KF-631 DL TR	300	204	172	28	32	37	50	55	100	8,5	M10	85	1,11
KF-631 DIL	300	189	172	56	32	37	50	55	100	8,5	M10	85	0,98
KF-631 DIL TR	300	204	172	56	32	37	50	55	100	8,5	M10	85	1,11
KF-631 RL	300	201	172	40	32	6,5	50		100	8,5	M10	85	0,98
KF-631 RL TR	300	216	172	40	32	6,5	50		100	8,5	M10	85	1,11
KF-631 RIL	300	201	172	68	32	6,5	50		100	8,5	M10	85	0,98
KF-631 RIL TR	300	216	172	68	32	6,5	50		100	8,5	M10	85	1,11

GRAMPOS VERTICAIS



KF-017 DT



KF-017 DTS



KF-017 RTL

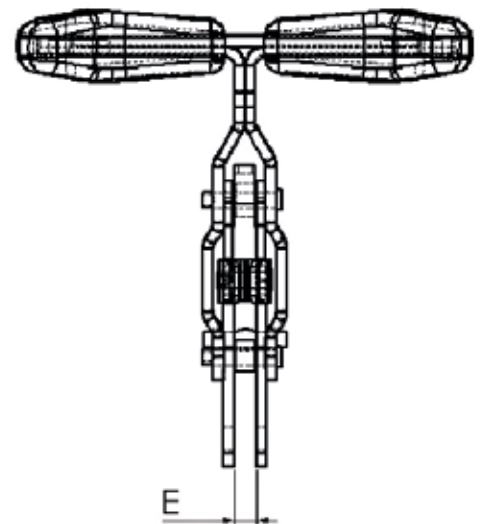
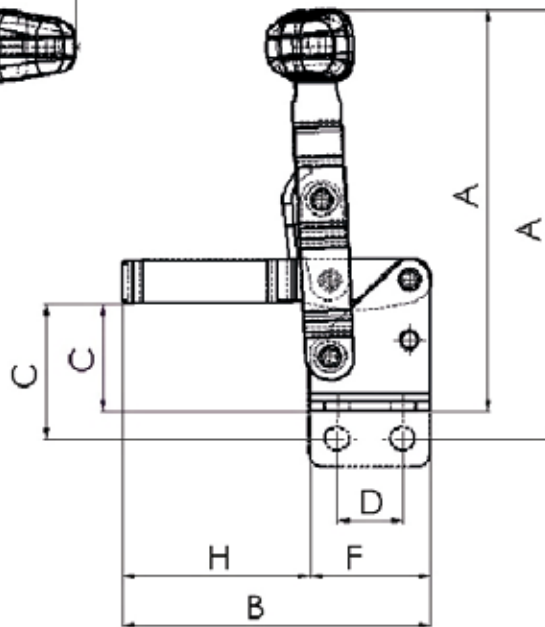
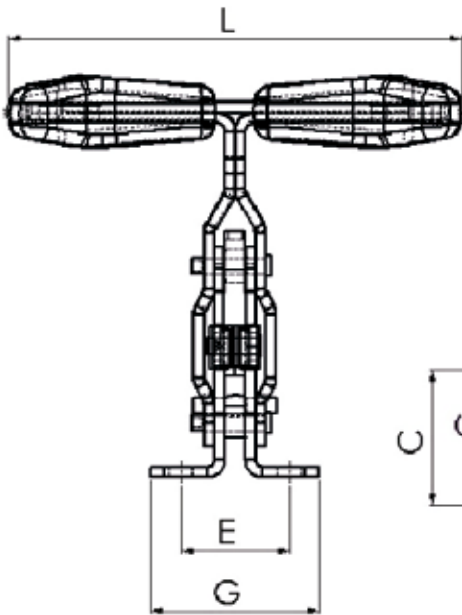

BASES
D - Dobrada
R - Retá

HASTES
S - Sólida
L - Longa

CABO
T - Cabo "T"

REFERÊNCIA	FORÇA DE RETENÇÃO KGF	A	B	C	D	E	F	G	H	J	L	PONTEIRA	ÂNGULO DE ABERTURA	PESO KG
KF-017 DT	170	120	90	32	19	32	35	49	55	7,0	132	M8	100	0,405
KF-017 DTL	150	120	120	32	19	32	35	49	85	7,0	132	M8	100	0,415
KF-017 DTS	200	120	120	32	19	32	35	49	85	7,0	132	M8	100	0,415
KF-017 RT	170	128	90	40	19	6,5	35		55	7,0	132	M8	100	0,405
KF-017 RTL	150	128	120	40	19	6,5	35		85	7,0	132	M8	100	0,415
KF-017 RTS	200	128	120	40	19	6,5	35		85	7,0	132	M8	100	0,415

GRAMPOS VERTICAIS

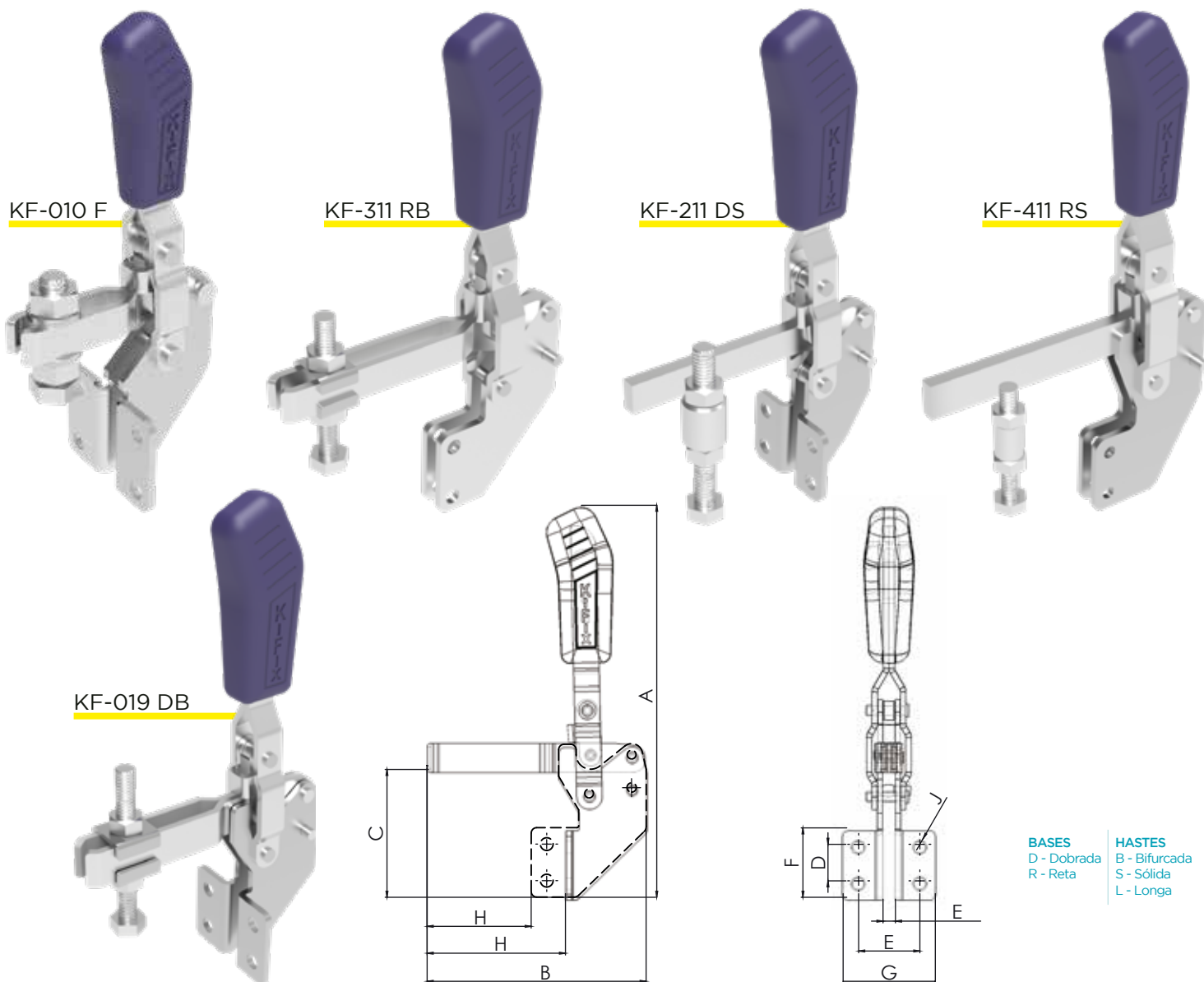

*Grampos enviados com ponteira de borracha

REFERÊNCIA	FORÇA DE RETENÇÃO KGF	A	B	C	D	E	F	G	H	J	PONTEIRA	ÂNGULO DE ABERTURA	PESO KG
KF-010 F*	32	112	51	42	16	23,7	25	33	24	4,3	M6	100	0,1
KF-012 F*	90	149	70	47	12,7	27	25	40	41	5,5	M6	100	0,23
KF-019 DB	250	215	120	70	20	33,5	38	50,5	76	7,0	M8	100	0,5
KF-019 DS	250	215	120	70	20	33,5	38	50,5	76	7,0	M8	100	0,5
KF-019 RB	250	215	120	70	20	6,5	38		57	7,0	M8	100	0,5
KF-019 RS	250	215	120	70	20	6,5	38		57	7,0	M8	100	0,5
KF-211 DB	150	207	120	65	19	32	35	46,5	79	7,0	M8	100	0,48
KF-211 DS	200	207	120	65	19	32	35	46,5	79	7,0	M8	100	0,48
KF-211 RB	150	207	120	65	19	6,5	35		69	7,0	M8	100	0,48
KF-211 RS	200	207	120	65	19	6,5	35		69	7,0	M8	100	0,48
KF-311 DB	250	260	166	90	32	44	49	60	106	8,5	M10	100	0,96
KF-311 DS	300	260	166	90	32	44	49	60	106	8,5	M10	100	0,93
KF-311 RB	250	260	166	90	32	8	49		97	8,5	M10	100	0,96
KF-311 RS	300	260	166	90	32	8	49		97	8,5	M10	100	0,93
KF-411 DB	650	321	200	113	32	45	55	67	134	8,5	M10	100	1,75
KF-411 DS	700	321	200	113	32	45	55	67	134	8,5	M10	100	1,7
KF-411 RB	650	321	200	113	32	10	55		126	8,5	M10	100	1,75
KF-411 RS	700	321	200	113	32	10	55		126	8,5	M10	100	1,7

GRAMPOS VERTICAIS



KF-615 B



KF-641 DS

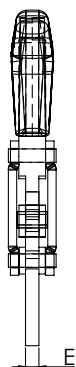
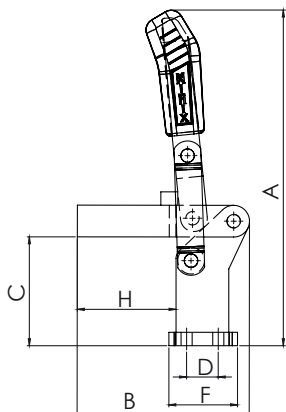
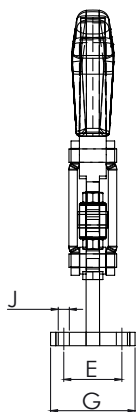
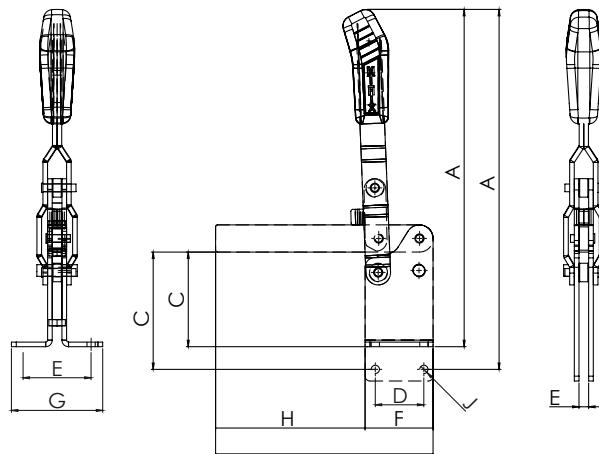

KF-066 STR



KF-066 TS



KF-875

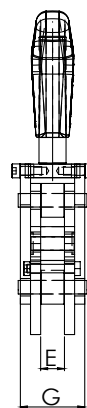
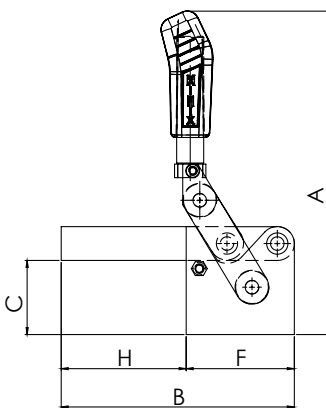
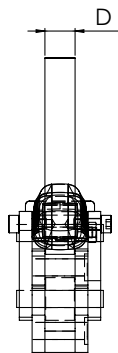

BASES
 D - Dobrada
 R - Retá
 T - Base T

HASTES
 B - Bifurcada
 S - Sólida
 L - Longa

TR - Trava

REFERÊNCIA	FORÇA DE RETENÇÃO KGF	A	B	C	D	E	F	G	H	J	PONTEIRA	ÂNGULO DE ABERTURA	PESO KG
KF-615 B	340	215	108	42	25,4	38,1	50,8	50,8	57	7,0	M8	125	0,92
KF-615 BL	340	215	191	42	25,4	38,1	50,8	50,8	140	7,0	M8	125	0,92
KF-616 D	950	249	155	50	32	45	53,5	67	101,5	7,0	M10	125	1,35
KF-616 R	950	257	155	58	32	9,5	53,5		101,5	7,0	M10	125	1,35
KF-641 DB	800	347	224	98	50	70	70	94	154	8,5	M10	85	2,25
KF-641 RB	800	371	224	121	50	10	70		154	8,5	M10	85	2,25
KF-641 DS	800	347	224	98	50	70	70	94	154	8,5	M10	85	2,25
KF-641 RS	800	371	224	121	50	10	70		154	8,5	M10	85	2,25
KF-066 S	1400	305	163	90		12,7	50		93		M12	150	3,3
KF-066 S TR	1400	305	163	90		12,7	50		93		M12	150	3,8
KF-066 TS	1400	318	163	103	30	55	65	80	93	10,5	M12	150	3,8
KF-066 TS TR	1400	318	163	103	30	55	65	80	93	10,5	M12	150	4,3
KF-845	1150	246	190	56,2	19	19	82	50,9	108		M12	120	3,35
KF-875	1800	304	219	69,7	22,4	22,4	101,6	60,5	117,4		M12	90	5,6

GRAMPOS VERTICAIS



KF-011 DS A

KF-011 DS A JD

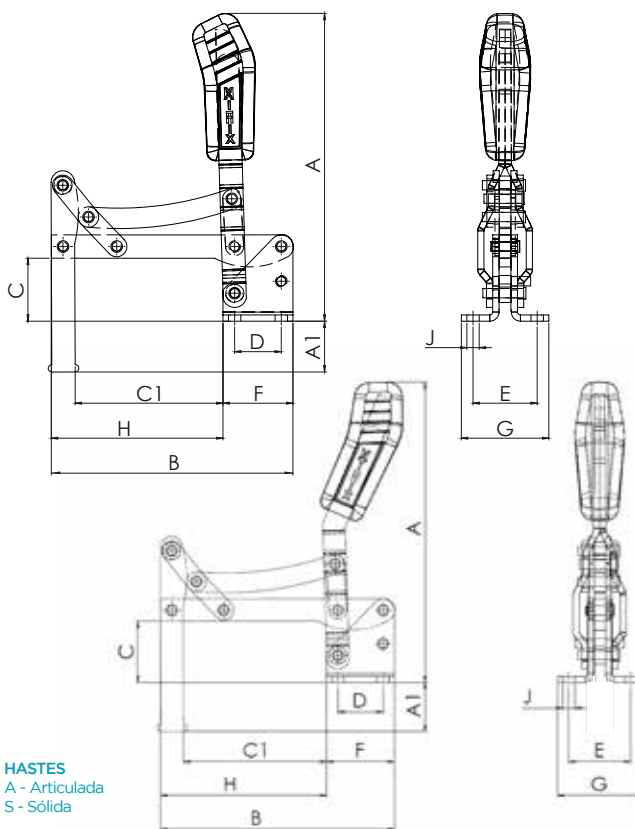

BASES
D - Dobrada

HASTES
A - Articulada
S - Sólida

REFERÊNCIA	FORÇA DE RETENÇÃO KGF	A	A1	B	C	C1	D	E	F	G	H	J	PONTEIRA	ÂNGULO DE ABERTURA	PESO KG
KF-017 DS A	160	175	29	120	32	73	19	32	35	49	85	7,0	M6	90	0,530
KF-011 DS A	240	211	35	166	41	101	32	44	48	60	118	8,5	M8	90	1,150
KF-011 DS A JD	240	211	35	166	41	101	32	44	48	60	118	8,5	M8	90	1,150
KF-111 DS A	560	258	43	200	50	125	32	45	55	67	145	8,5	M10	90	2,050

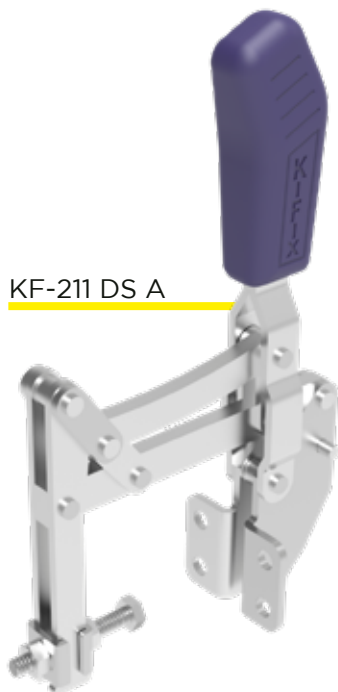

KF-211 DS A

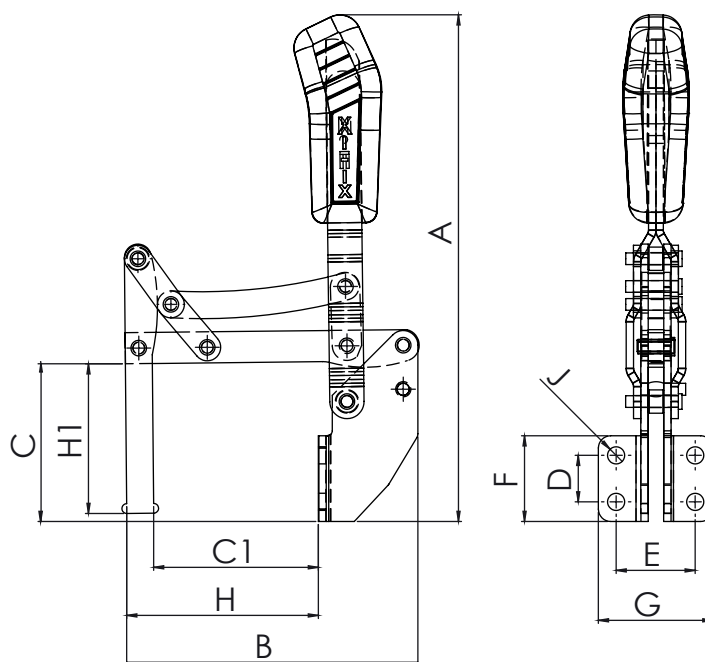

BASES
D - Dobrada

HASTES
A - Articulada
S - Sólida

REFERÊNCIA	FORÇA DE RETENÇÃO KGF	A	B	C	C1	D	E	F	G	H	H1	J	PONTEIRA	ÂNGULO DE ABERTURA	PESO KG
KF-211 DS A	160	207	120	65	67,5	19	32	35	46,5	79	61	7,0	M6	100	0,560
KF-311 DS A	240	260	166	90	90	32	44	49	60	106	78	8,5	M8	100	1,240
KF-411 DS A	560	321	200	113	114	32	45	55	67	134	92	8,5	M10	100	2,250

GRAMPOS VERTICAIS

KF-MP

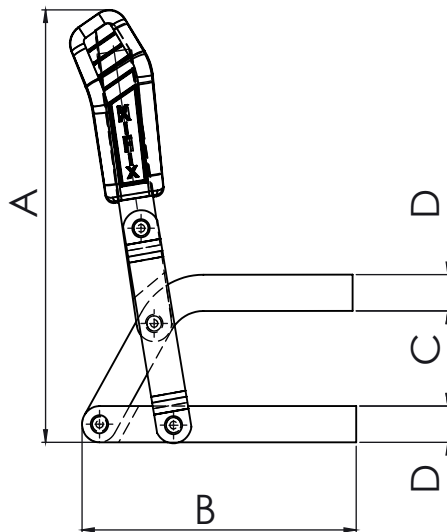
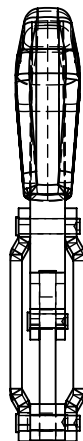
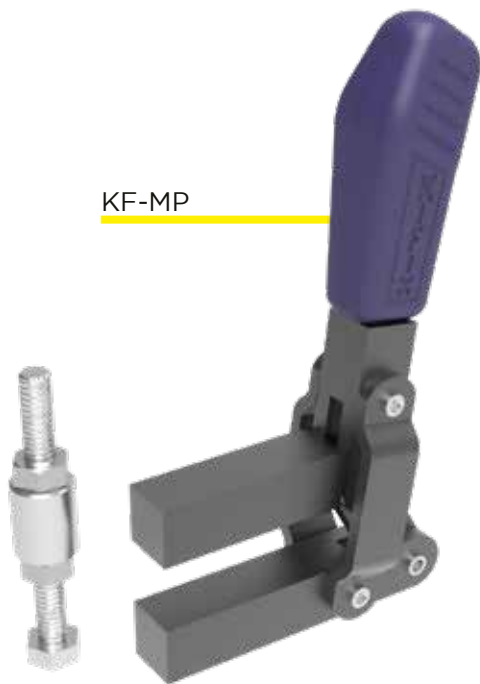

REFERÊNCIA	FORÇA DE RETENÇÃO KGF	A	B	C	D	PONTEIRA	ÂNGULO DE ABERTURA	PESO KG
KF-01 MP	160	125	70	15	12,7	M6	120	0,320
KF-02 MP	300	171	92	20	14,3	M8	120	0,580
KF-03 MP	450	191	101	30	15,8	M8	120	1,350
KF-05 MP	500	227	150	50	19,1	M10	120	2,040
KF-06 MP	500	247	161	60	19,1	M10	120	2,135
KF-09 MP	1800	324	200	90	25,4	M12	120	4,250

KF-JD

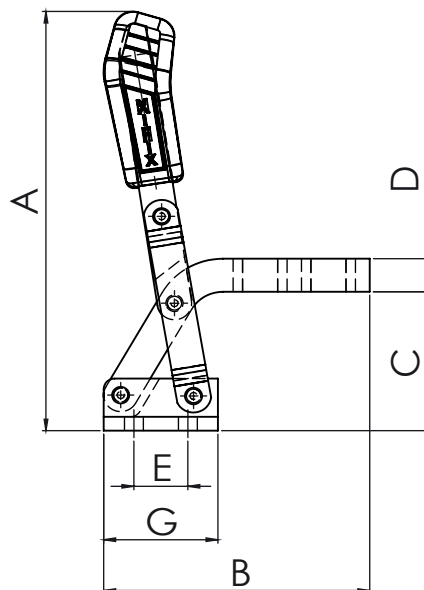
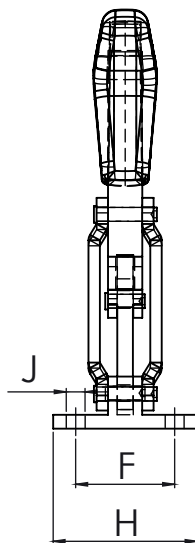

REFERÊNCIA	FORÇA DE RETENÇÃO KGF	A	B	C	D	E	F	G	H	J	PONTEIRA	ÂNGULO DE ABERTURA	PESO KG
KF-03 JD	450	206	101	56	15,8	32	44	48	60	8,5	M8	120	1,360
KF-05 JD	500	241	148	80	19,1	30	55	63,5	80	10,5	M10	120	2,100

GRAMPOS VERTICAIS

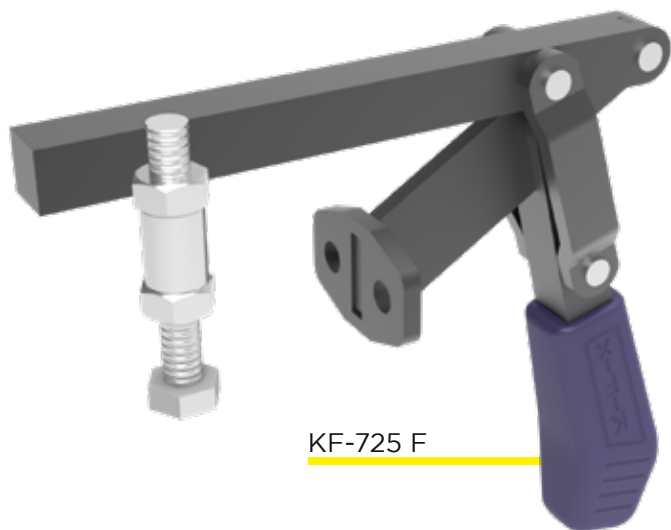

KF-725 F

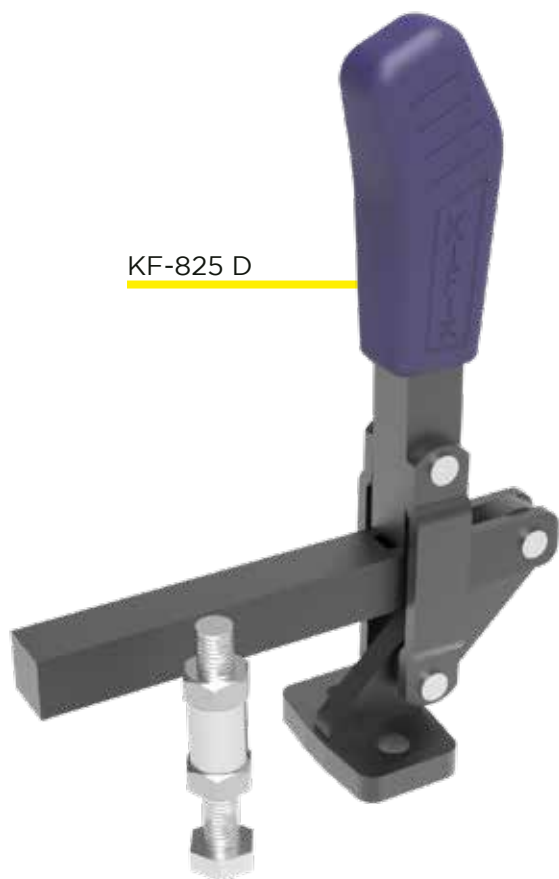
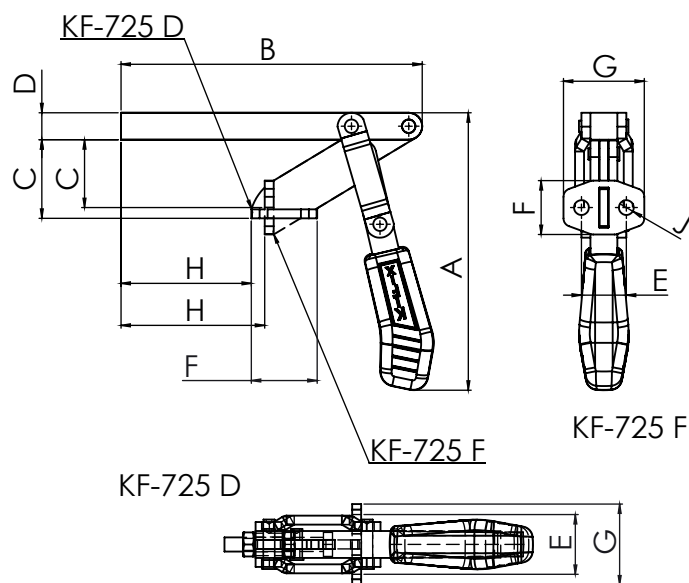

KF-825 D

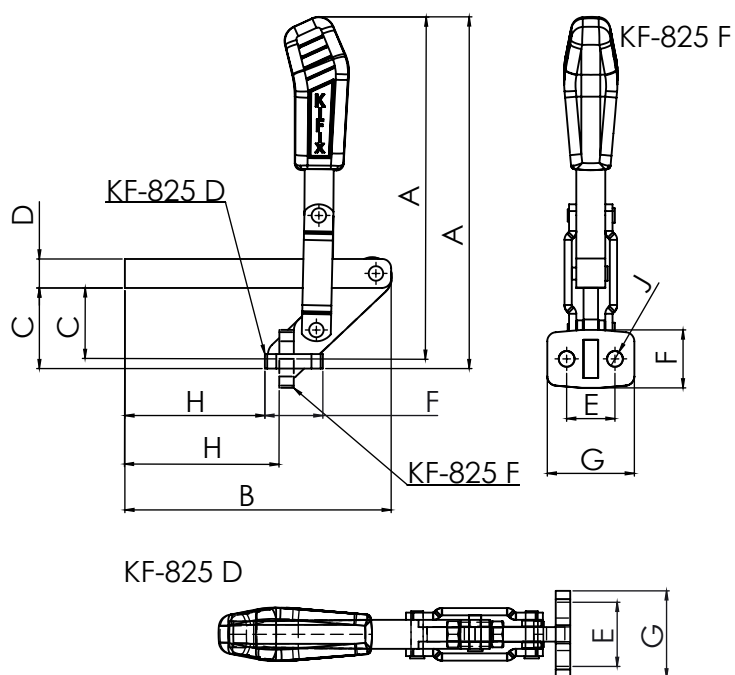

BASES
D - Dobrada
F - Frontal

REFERÊNCIA	FORÇA DE RETENÇÃO KGF	A	B	C	D	E	F	G	H	J	PONTEIRA	ÂNGULO DE ABERTURA	PESO KG
KF-725 D	450	196	213	55,6	19	32	38,1	57,2	92,2	10,5	M10	195	2,03
KF-725 F	450	196	213	48	19	32	38,1	57,2	101,6	10,5	M10	195	2,03
KF-825 D	450	231	175	53	19	32	38,1	57,2	92,2	10,5	M10	195	1,85
KF-825 F	450	225	175	46,7	19	32	38,1	57,2	101,6	10,5	M10	195	1,85

GRAMPOS VERTICAIS

KFU A
Base triangular

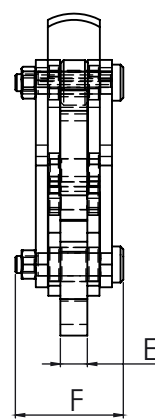
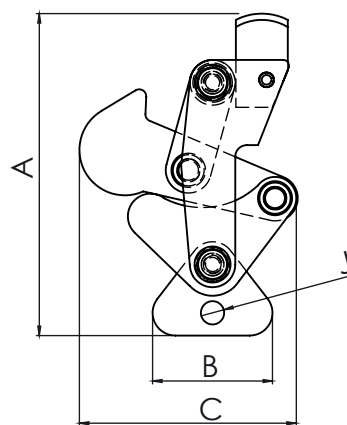

KFU D
Base T

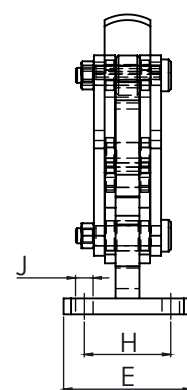
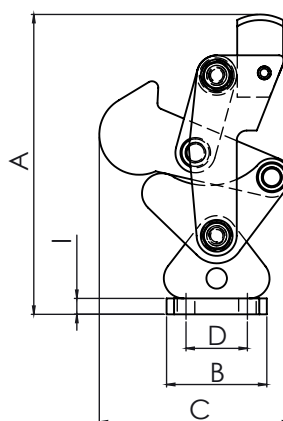

KFU R
Base reta dupla

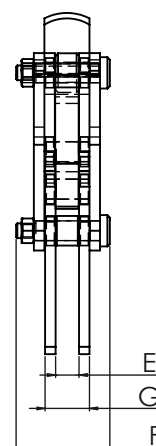
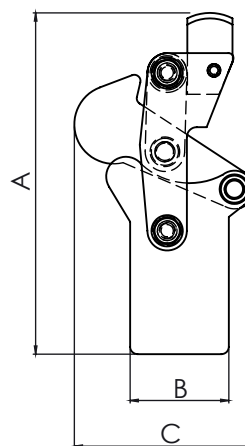

REFERÊNCIA	FORÇA DE RETENÇÃO KGF	A	B	C	D	E	F	G	H	I	J	PONTEIRA	ÂNGULO DE ABERTURA	PESO KG
KFU-03 A	680	105	42	72		9,5	42				8,5	M6	200	0,67
KFU-03 D	680	112	40	72	24,5	51	42		34,5	6,35	7,0	M6	200	0,76
KFU-03 R	680	130	40	68		9,5	42	18				M6	200	0,73
KFU-05 A	1000	145	60	98		12,7	47				10,5	M10	200	1,17
KFU-05 D	1000	153	55	98	31,5	64	47		45	8	8,5	M10	200	1,38
KFU-05 R	1000	170	50	92		12,7	47	22				M10	200	1,24
KFU-06 A	2200	176	70	118		15,9	66				12,5	M10	200	2,72
KFU-06 D	2200	186	70	118	40	80	66		50	9,5	10,5	M10	200	3,11
KFU-06 R	2200	211	65	114		15,9	66	29				M10	200	2,9
KFU-08 A	3500	247	84	177		19	72,5				13,0	M12	200	6,44
KFU-08 D	3500	260	100	177	70	150	72,5		120	12,7	10,5	M12	200	7,83
KFU-08 R	3500	273	80,6	177		19	72,5	35				M12	200	6,27

GRAMPOS HORIZONTAIS

KF-105 D

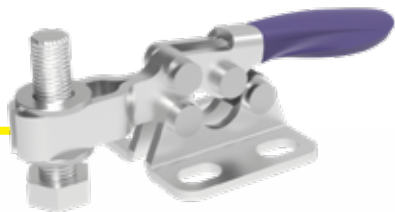

KF-106 D

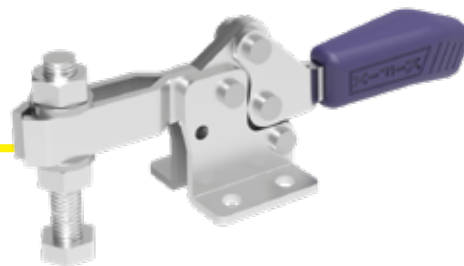

KF-105 DU



KF-107 D

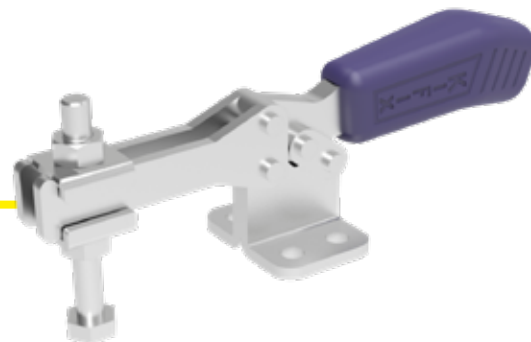

KF-732 R

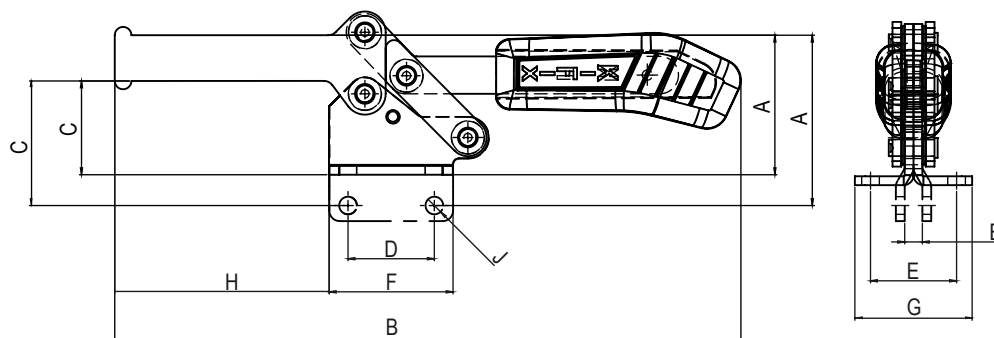
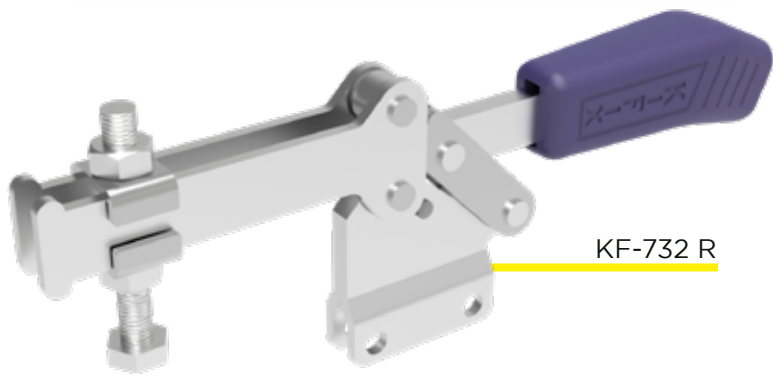

BASES
D - Dobrada
R - Reta
DU - Dobrada única

*Grampos enviados com ponteira de borracha

REFERÊNCIA	FORÇA DE RETENÇÃO KGF	A	B	C	D	E	F	G	H	J	PONTEIRA	ÂNGULO DE ABERTURA	PESO KG
KF-105 D*	30	18	64	8	13,5	16	24	24	18,6	4,3	M4	90	0,030
KF-105 DU*	30	21,3	64	8	13,5	8	24	12	18,6	4,3	M4	90	0,030
KF-105 R*	30	24	64	12	13,5		24		18,6	4,3	M4	90	0,030
KF-106 D*	70	35	112	20	13,5	18,3	25,5	28	35	4,5	M6	90	0,095
KF-106 R*	70	40	112	24	13,5	4	25,5		35	4,5	M6	90	0,095
KF-107 D*	70	45	136	22	12,7	12	26	35	51	5,5	M6	70	0,180
KF-152 D	130	46	184	25	20	25,5	38	37	58	7,0	M6	90	0,280
KF-152 R	130	54	184	32	20	6	38		58	7,0	M6	90	0,280
KF-732 D	340	79	301	45	42	42	60	57	103	8,5	M10	80	1,030
KF-732 R	340	93	301	60	42	8,5	60		103	8,5	M10	80	1,030

GRAMPOS HORIZONTAIS

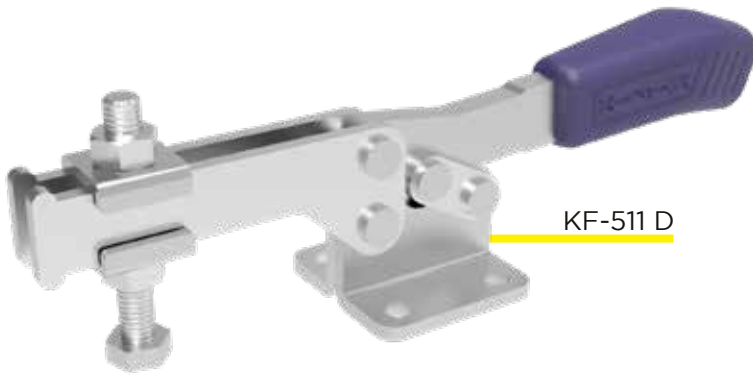

KF-511 D

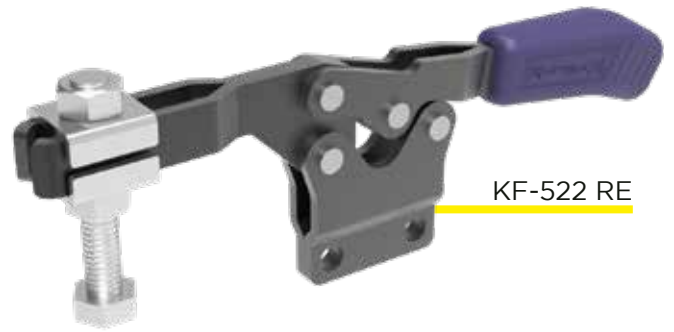

KF-522 RE

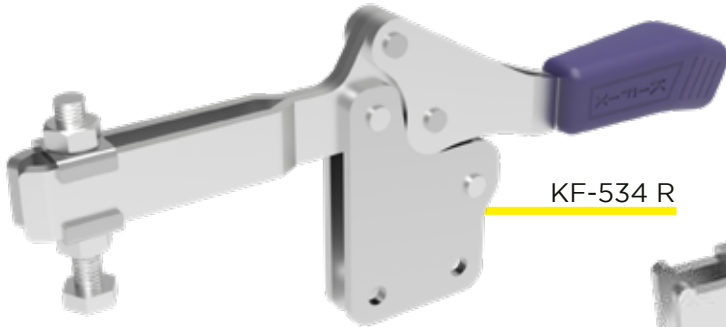

KF-534 R

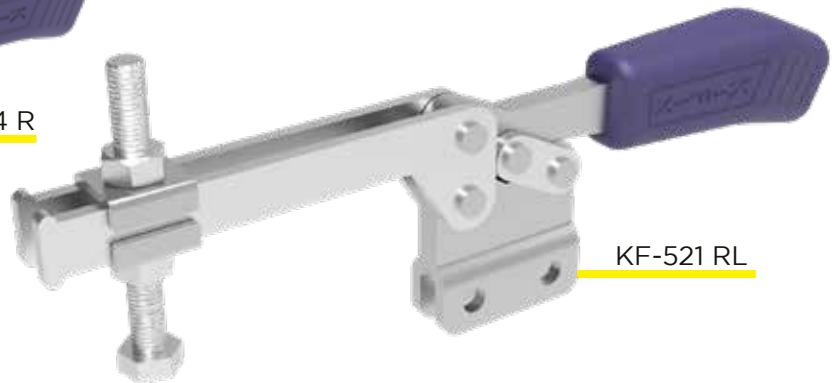

KF-521 RL

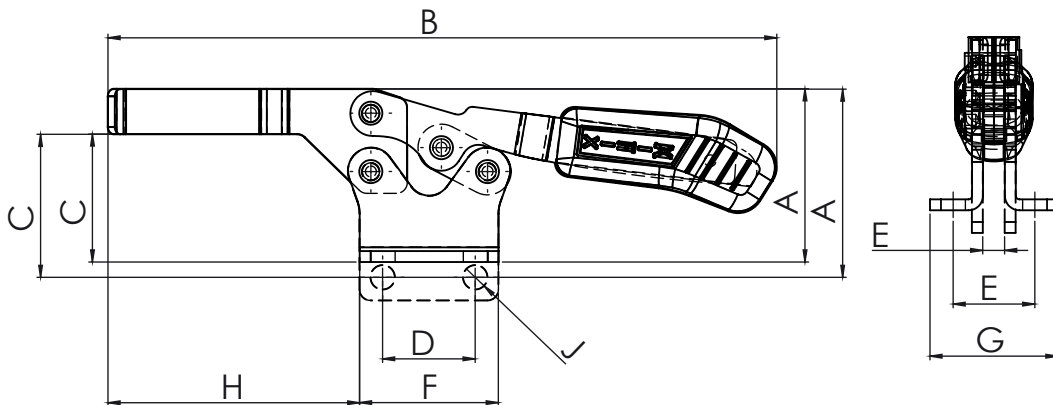

BASES
 D - Dobrada
 R - Reta
 E - Especial

HASTES
 L - Longa
 TR - Trava

REFERÊNCIA	FORÇA DE RETENÇÃO KGF	A	B	C	D	E	F	G	H	J	PONTEIRA	ÂNGULO DE ABERTURA	PESO KG
KF-511 D	90	47	172	26	24	26	36	37	59	5,5	M6	70	0,240
KF-511 R	90	55	172	34	24	6,5	36		59	5,5	M6	70	0,240
KF-512 D	90	39	146	26	25,4	22,4	37	35	57	5,3	M6	90	0,150
KF-512 R	90	45	146	32	25,4	4,5	37		57	5,3	M6	90	0,150
KF-521 D	130	51	208	36	25,4	24	45	42	68	7,0	M8	70	0,440
KF-521 D TR	130	51	235	36	25,4	24	45	42	68	7,0	M8	70	0,480
KF-521 DL	100	51	243	36	25,4	24	45	42	103	7,0	M8	70	0,470
KF-521 R	130	57	208	42	25,4	6,5	45		68	7,0	M8	70	0,440
KF-521 RL	100	57	243	42	25,4	6,5	45		103	7,0	M8	70	0,470
KF-522 D	230	48	184	35	25,4	22,4	38	35	69	6,7	M8	90	0,295
KF-522 R	230	52	184	39	25,4	6	38		69	6,7	M8	90	0,295
KF-522 RE	230	52	184	39	25,4	0	38		69	6,7	M8	90	0,295
KF-532 D	340	65	294	45	41	42	57	58	105	8,5	M10	90	0,860
KF-532 R	340	76	294	56	41	8,5	57		105	8,5	M10	90	0,860
KF-532 D TR	340	65	294	45	41	42	57	58	105	8,5	M10	90	0,920
KF-534 D	450	107,7	335	57,2	41,3	41,3	66,7	66,7	123,7	8,5	M10	100	1,450
KF-534 R	450	116	335	65,4	41,3	9,5	66,7		123,7	8,5	M10	100	1,450

GRAMPOS HORIZONTAIS

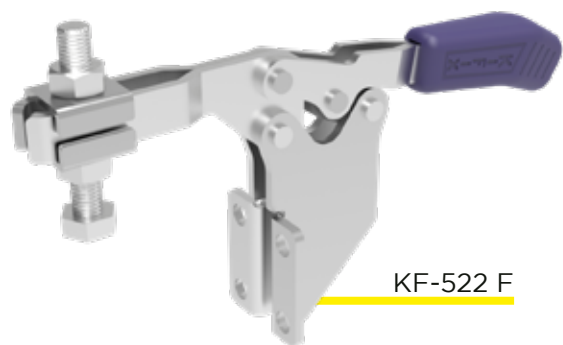

KF-522 F

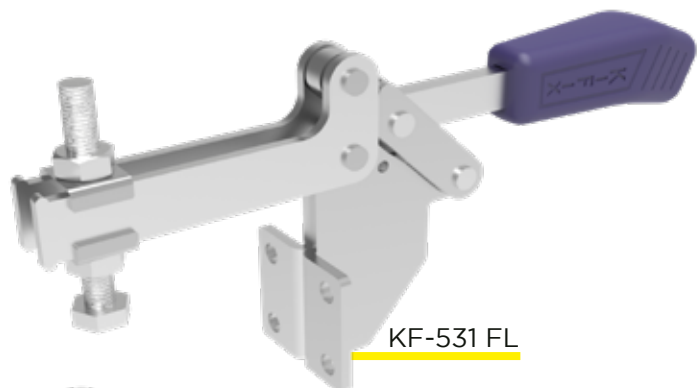
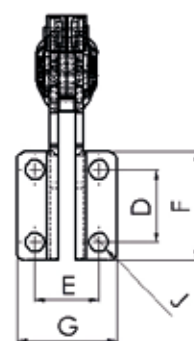
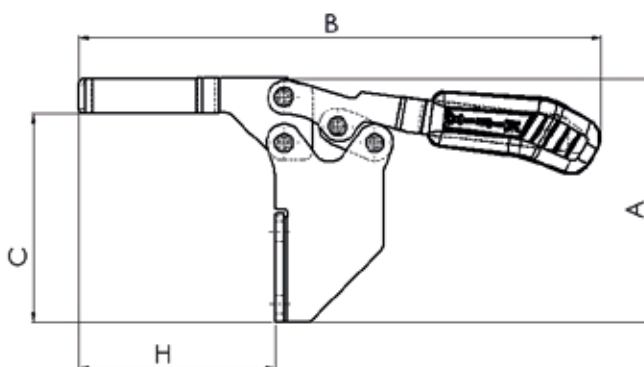

KF-531 FL

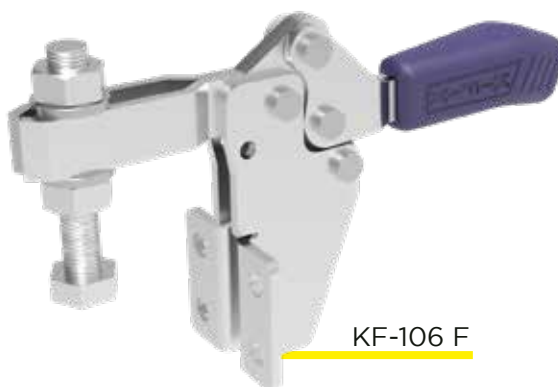

KF-106 F

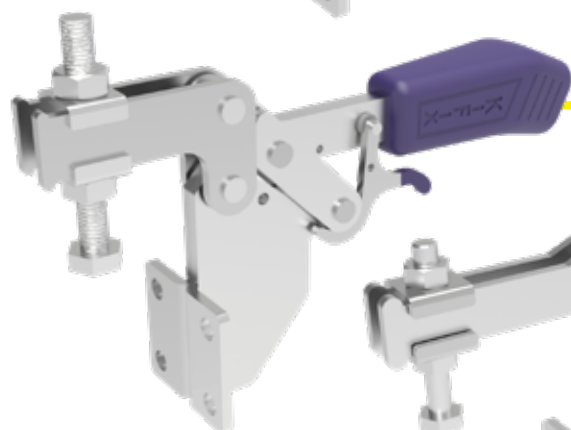

KF-531 FI TR

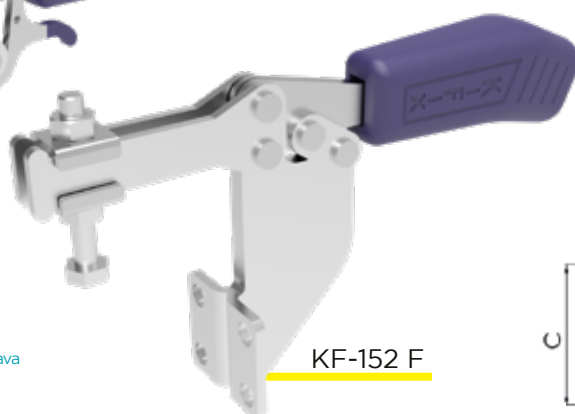
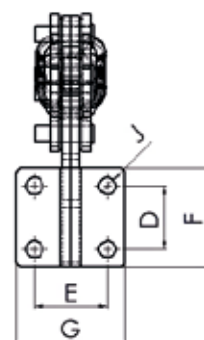

KF-152 F

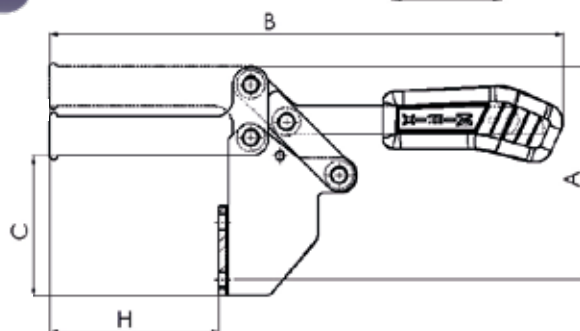

BASES
F - Frontal

HASTES
L - Longa
I - Invertida

TR - Trava

*Grampos enviados com ponteira de borracha

REFERÊNCIA	FORÇA DE RETENÇÃO KGF	A	B	C	D	E	F	G	H	J	PONTEIRA	ÂNGULO DE ABERTURA	PESO KG
KF-106 F*	70	56	112	40	13,5	18,3	25,5	28	35	4,5	M6	90	0,110
KF-107 F*	70	74	127	31	12,7	22	25	35	47	5,5	M6	70	0,200
KF-312 F	70	59	117	42	13,5	18,6	25,5	28	41	5,0	M6	90	0,103
KF-152 FL	90	95	201	74	20	25,5	32	37	70	7,0	M6	90	0,343
KF-152 F	130	95	184	74	20	25,5	32	37	52	7	M8	90	0,34
KF-522 F	230	85	184	73	25,4	22,4	38	35	69	6,7	M8	90	0,335
KF-522 FL	200	85	214	73	25,4	22,4	38	35	99	6,7	M8	90	0,350
KF-531 F	400	119	245	78	32	37	50	55	52	8,5	M8	80	1,035
KF-531 FI	400	119	245	106	32	37	50	55	52	8,5	M8	80	1,035
KF-531 FL	300	119	287	78	32	37	50	55	95	8,5	M8	80	1,095
KF-531 FIL	300	119	287	106	32	37	50	55	95	8,5	M10	80	1,095
KF-531 F TR	400	119	245	78	32	37	50	55	52	8,5	M10	80	1,070
KF-531 FI TR	400	119	245	106	32	37	50	55	52	8,5	M10	80	1,070
KF-531 FL TR	300	119	287	78	32	37	50	55	95	8,5	M10	80	1,130
KF-531 FIL TR	300	119	287	106	32	37	50	55	95	8,5	M10	80	0,343

GRAMPOS HORIZONTAIS



KF-531 D TR

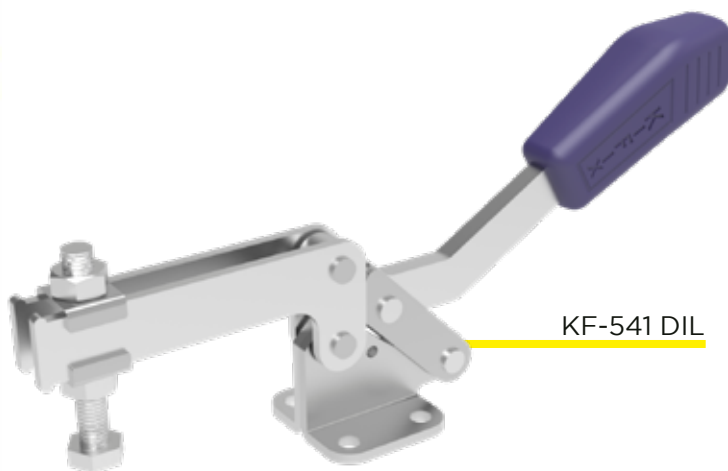

KF-541 DIL

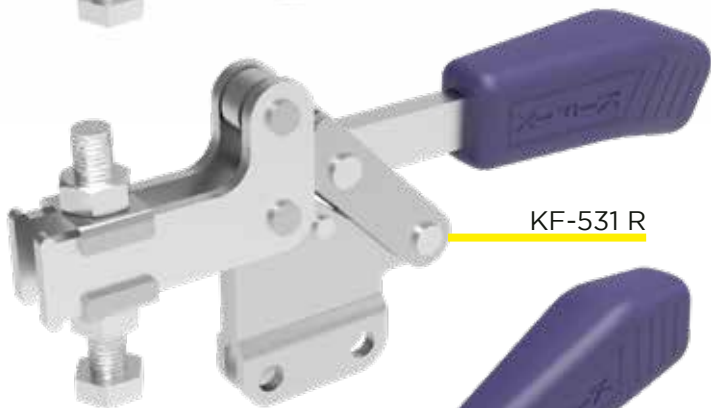

KF-531 R

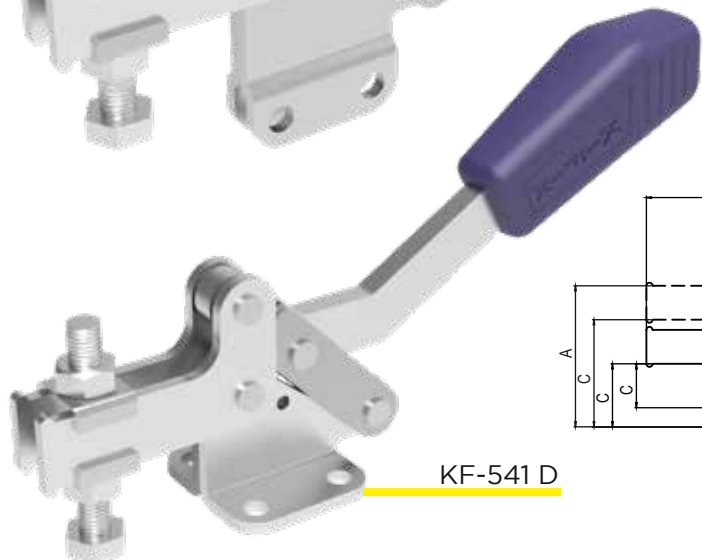

KF-541 D

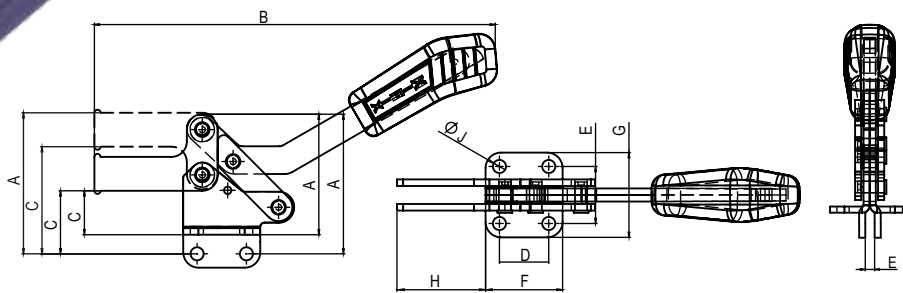
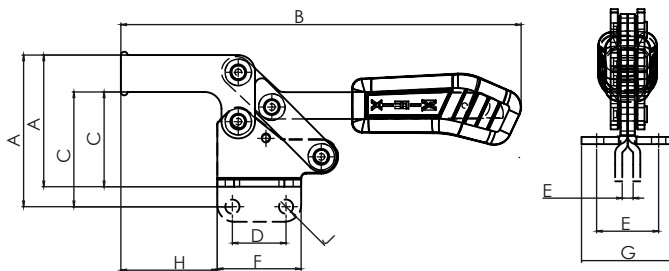

BASES
D - Dobrada
R - Reta

HASTES
L - Longa
TR - Trava

REFERÊNCIA	FORÇA DE RETENÇÃO KGF	A	B	C	D	E	F	G	H	J	PONTEIRA	ÂNGULO DE ABERTURA	PESO KG
KF-531 D	400	78	239	28	32	37	50	55	57	8,5	M10	80	0,870
KF-531 DI	400	78	239	56	32	37	50	55	57	8,5	M10	80	0,870
KF-531 R	400	91	239	41	32	6,5	50		57	8,5	M10	80	0,870
KF-531 RI	400	91	239	69	32	6,5	50		57	8,5	M10	80	0,870
KF-531 DL	300	78	281	28	32	37	50	55	100	8,5	M10	80	0,940
KF-531 DIL	300	78	281	56	32	37	50	55	100	8,5	M10	80	0,940
KF-531 RL	300	91	281	41	32	6,5	50		100	8,5	M10	80	0,940
KF-531 RIL	300	91	281	69	32	6,5	50		100	8,5	M10	80	0,940
KF-531 D TR	400	78	245	28	32	37	50	55	57	8,5	M10	80	0,920
KF-531 DI TR	400	78	245	56	32	37	50	55	57	8,5	M10	80	0,920
KF-531 DL TR	300	78	287	28	32	37	50	55	100	8,5	M10	80	0,980
KF-531 DIL TR	300	78	287	56	32	37	50	55	100	8,5	M10	80	0,980
KF-541 D	400	78	261	28	32	37	50	55	57	8,5	M10	80	0,920
KF-541 DI	400	78	261	56	32	37	50	55	57	8,5	M10	80	0,920
KF-541 R	400	91	261	41	32	6,5	50		57	8,5	M10	80	0,920
KF-541 RI	400	91	261	69	32	6,5	50		57	8,5	M10	80	0,920
KF-541 DL	300	78	304	28	32	37	50	55	100	8,5	M10	80	0,960
KF-541 DIL	300	78	304	56	32	37	50	55	100	8,5	M10	80	0,960
KF-541 RL	300	91	304	41	32	6,5	50		100	8,5	M10	80	0,960
KF-541 RIL	300	91	304	69	32	6,5	50		100	8,5	M10	80	0,960

GRAMPOS HORIZONTAIS

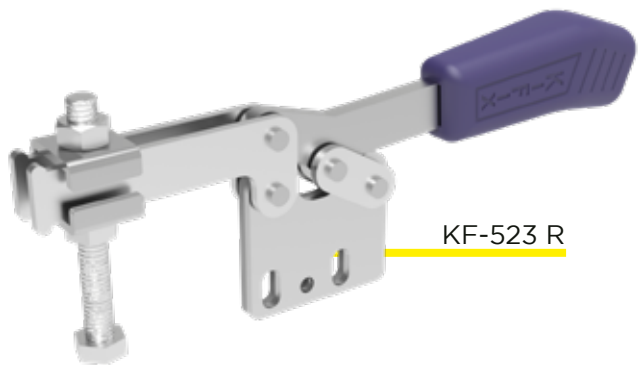

KF-523 R

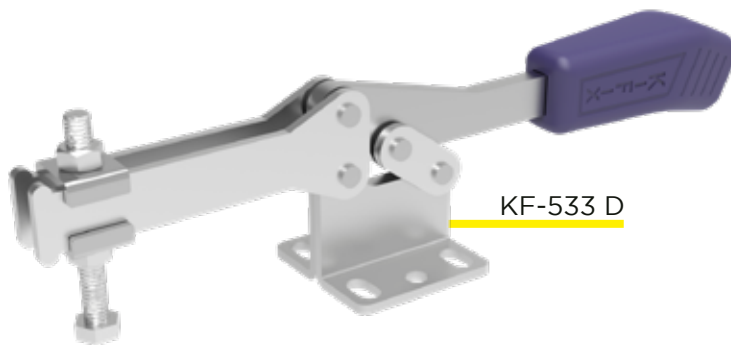

KF-533 D

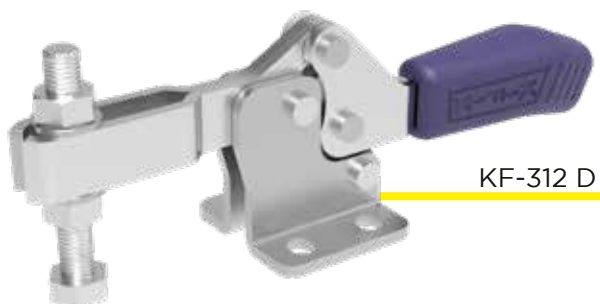

KF-312 D

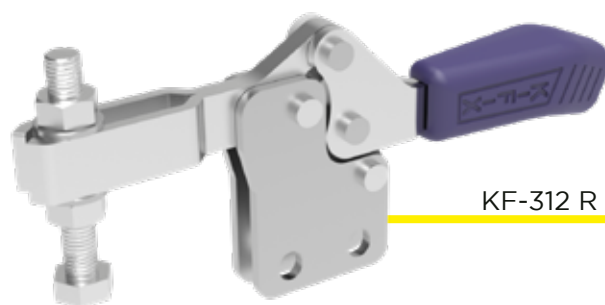

KF-312 R

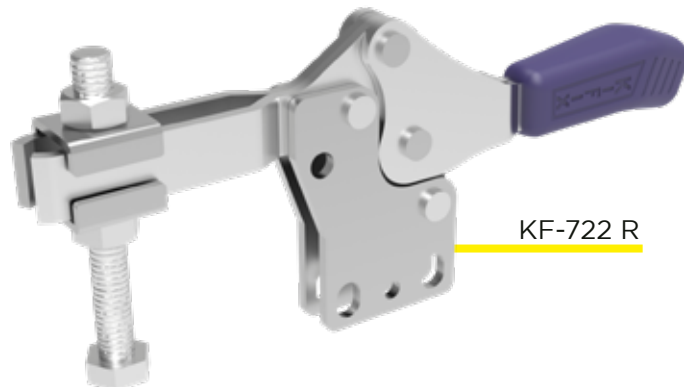
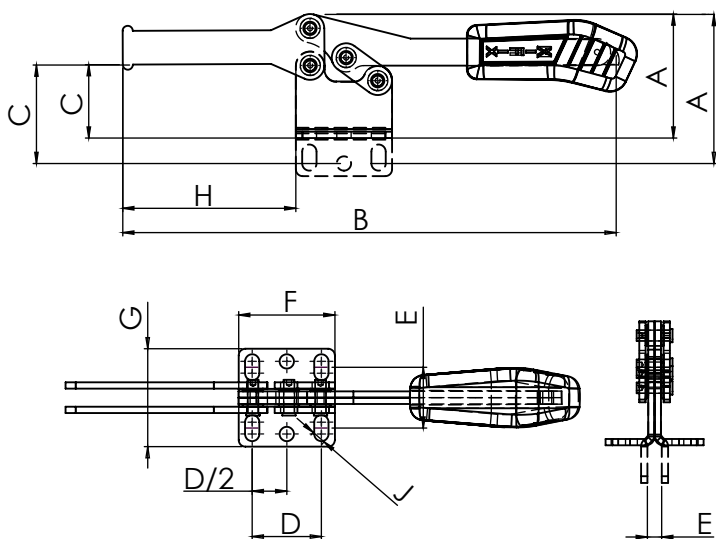

KF-722 R

BASES
D - Dobrada
R - Reta

*Grampos enviados com ponteira de borracha

REFERÊNCIA	FORÇA DE RETENÇÃO KGF	A	B	C	D	E	F	G	H	J	PONTEIRA	ÂNGULO DE ABERTURA	PESO KG
KF-312 D*	70	35	112	19	13,5	17,3	25,4	27,2	36	4,3	M5	90	0,085
KF-312 R*	70	39	112	23	13,5	4,2	25,4		36	4,3	M5	90	0,085
KF-712 D	120	50	183	26	26,2	26,1	37,3	40	59	5,5	M6	90	0,205
KF-712 R	120	64	183	35	26,2	5,2	37,3		59	5,5	M6	90	0,205
KF-523 D	180	57	221	33	25,7	26,9	50	44,5	66	6,5	M8	90	0,410
KF-523 R	180	74	221	41	25,7	0	50		66	6,5	M8	90	0,410
KF-722 D	230	61	192	34	26,2	28,4	39,6	43,2	68,5	7,0	M8	90	0,355
KF-722 R	230	70	192	42	26,2	6,2	39,6		68,5	7,0	M8	90	0,355
KF-533 D	340	73,5	305	43,5	41	36	57	58	102,5	8,5	M8	90	0,800
KF-533 R	340	88,3	305	58,3	41	8,5	57		102,5	8,5	M8	90	0,800

GRAMPOS HORIZONTAIS



KF-102 D



KF-102 R CL

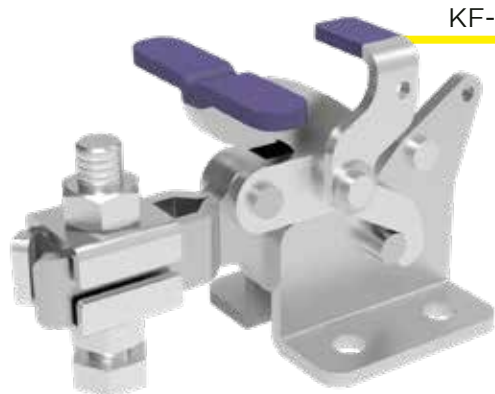

KF-103 D TR

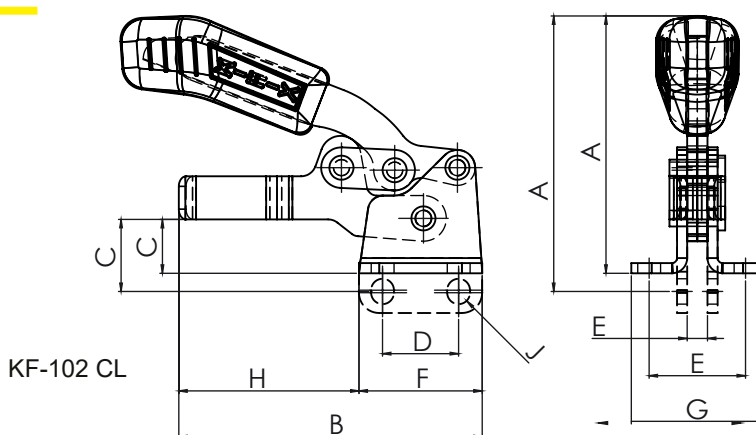

KF-102 CL

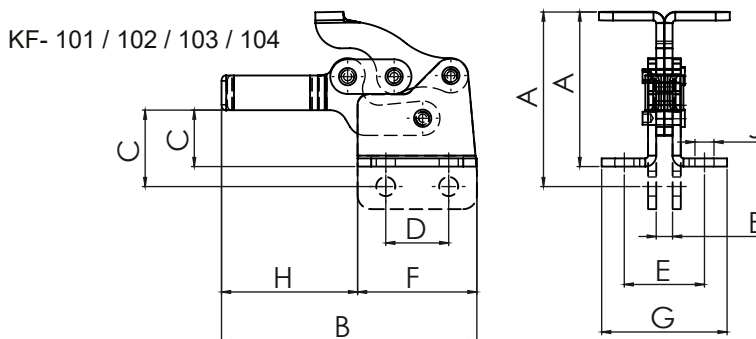

KF- 101 / 102 / 103 / 104

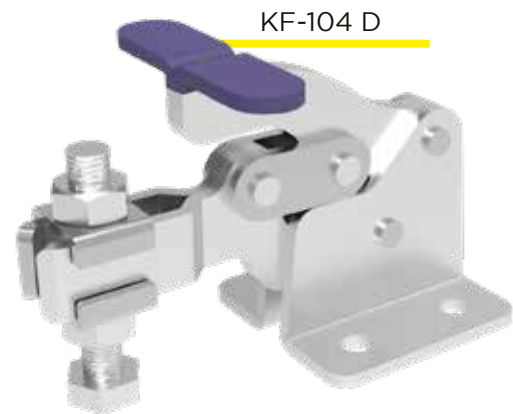

KF-104 D

BASES
D - Dobrada
R - Reta

HASTES
S - Sólida
CL - Cabo Longo

TR - Trava

*Grampos enviados com ponteira de borracha

REFERÊNCIA	FORÇA DE RETENÇÃO KGF	A	B	C	D	E	F	G	H	J	PONTEIRA	ÂNGULO DE ABERTURA	PESO KG
KF-102 D*	50	38	60	11	15	19	24	26	36	4,5	M6	75	0,075
KF-102 R*	50	42	60	14	15	4	24		36	4,5	M6	75	0,075
KF-102 D CL*	50	54	80	11	15	19	24	26	36	4,5	M6	75	0,085
KF-102 R CL*	50	58	80	14	15	4	24		36	4,5	M6	75	0,085
KF-101 D*	65	40	61	12,2	13,5	16	26	26	35	4,5	M6	75	0,075
KF-101 R*	65	43	61	15	13,5	4	26		35	4,5	M6	75	0,075
KF-103 D*	75	57	94	21	23	29	44	46	50	7,0	M6	85	0,260
KF-103 D TR*	75	57	94	21	23	29	44	46	50	7,0	M6	85	0,275
KF-103 R*	75	64	94	28	23	6	44		50	7,0	M6	85	0,260
KF-104 D	340	85,6	131,8	31,3	35	38,1	64	62,7	67,8	8,5	M6	90	0,670
KF-104 DS TR	340	85,6	112	31,2	35	38,1	64	62,7	48	8,5	M10	90	0,721
KF-104 R	340	95,9	131,8	41,6	35	7,5	64		67,8	8,5	M10	90	0,670

GRAMPOS TORPEDOS

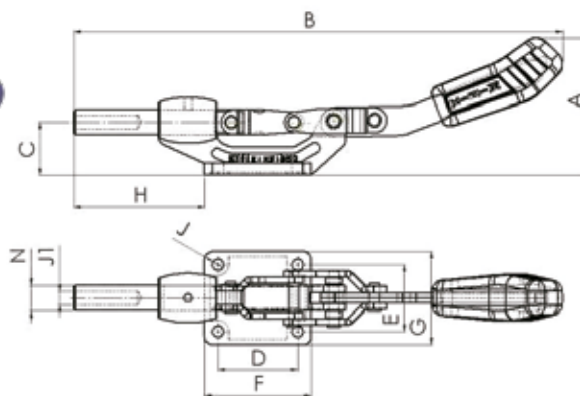
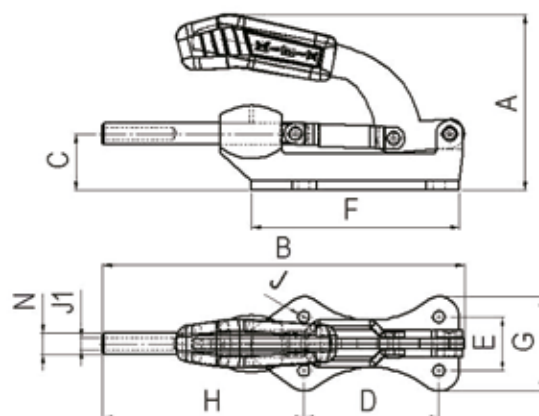
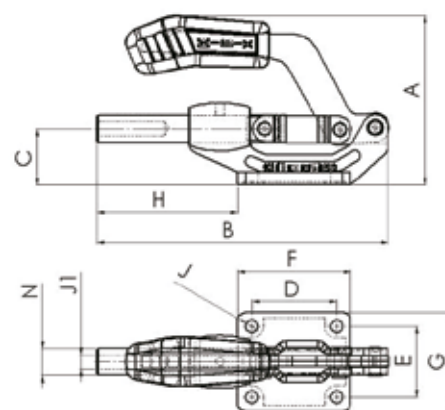

TR - Trava
IV - Ação Invertida
RF - Base Reforçada

REFERÊNCIA	FORÇA DE RETENÇÃO KGF	CURSO	A	B	C	D	E	F	G	H	J	J1	N	PONTEIRA	PESO KG
KF-061	50	16	51,3	66,1	13,7	16	16	35,4	26,7	22,5	4,3	M4X0,70	6,35	M4	0,070
KF-057	230	36	82	144	25	35	40	50	55	71	7,0	M8X1,25	12	M8	0,400
KF-057 TR	230	36	98	144	25	35	40	50	55	71	7,0	M8X1,25	12	M8	0,420
KF-057 IV	230	35	34	239	25	35	40	50	55	71	7,0	M8X1,25	12	M8	0,395
KF-051	270	35	92,2	125	24,8	36,6	33,3	58	48	57	6,3	M8X1,25	12	M8	0,390
KF-054	380	41	107,9	154	31,8	41,4	41,4	58,7	57,2	42,2	8,5	M10X1,50	16	M10	0,890
KF-054 IV	380	37	57,2	339	31,8	41,4	41,4	158	57,2	81	8,5	M10X1,50	16	M10	0,930
KF-053	500	83	127	268	42	100	40	154	70	149	8,5	M10X1,50	16	M10	2,150
KF-053 TR	500	83	134	268	42	100	40	154	70	149	8,5	M10X1,50	16	M12	2,220
KF-052	700	50	116	205	40	60	50	80	70	99	8,5	M12X1,75	19	M12	1,280
KF-052 TR	700	50	137	205	40	60	50	80	70	99	8,5	M12X1,75	19	M12	1,710
KF-052 IV	700	49	103	368	40	60	50	80	70	98	8,5	M12X1,75	19	M12	1,590
KF-052 RF	1200	50	120	205	40	60	50	80	70	99	8,5	M12X1,75	19	M16	1,660
KF-056	1800	78	150	287	57	100	60	162	86	162	10,5	M16X2,00	25	M16	3,500

GRAMPOS HORIZONTAIS REFORÇADOS

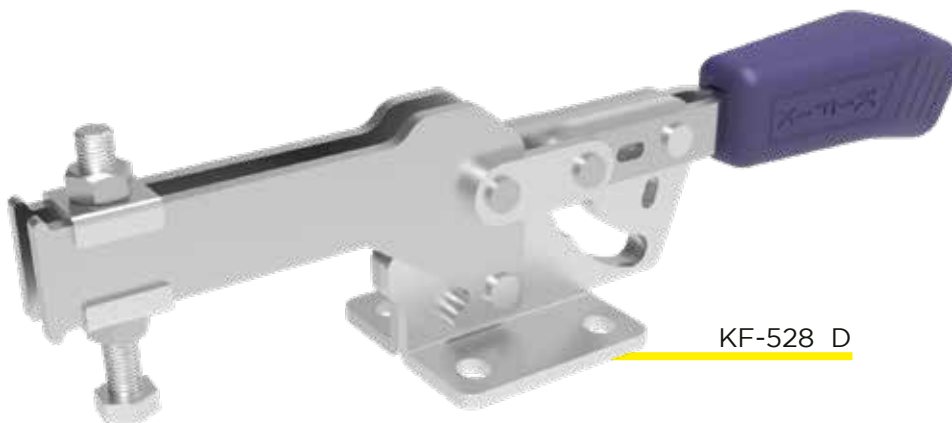

KF-528 D

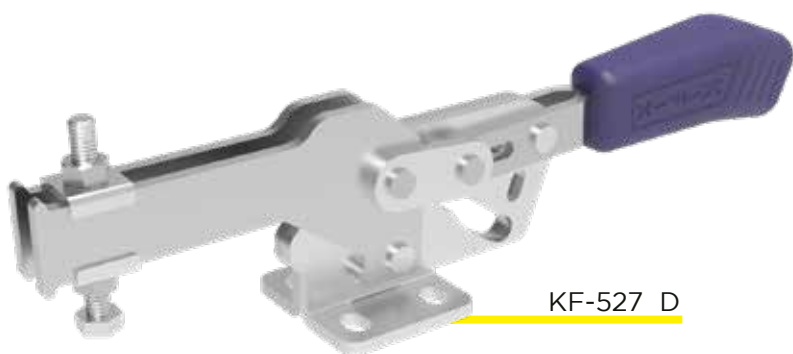

KF-527 D

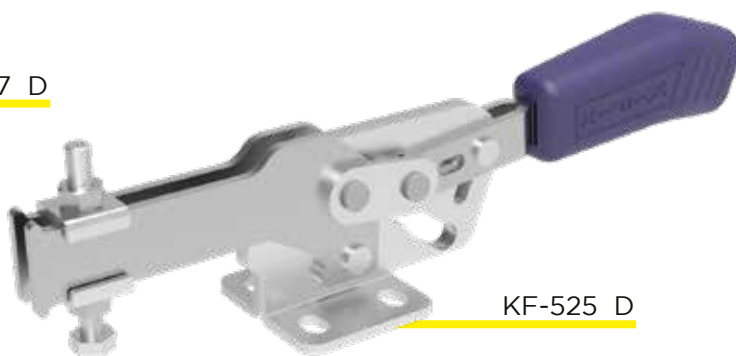

KF-525 D

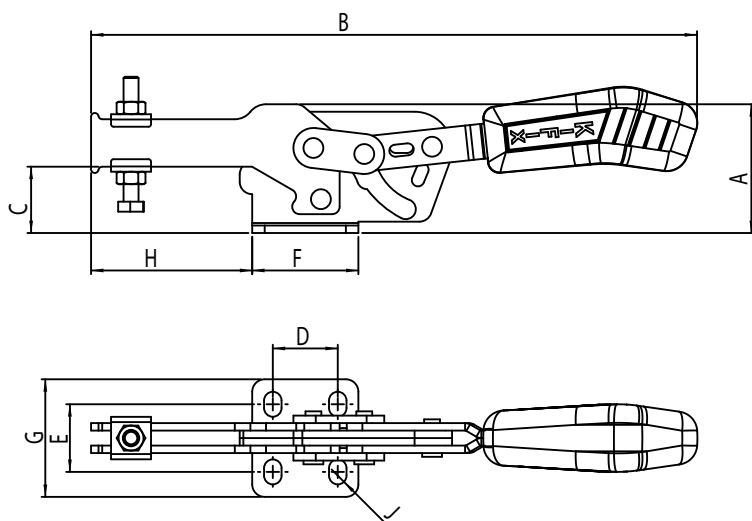

BASES
D - Dobrada

REFERÊNCIA	FORÇA DE RETENÇÃO KGF	A	B	C	D	E	F	G	H	J	ÂNGULO DE ABERTURA	PONTEIRA	PESO KG
KF-524 D	130	34,4	167	19	13,5	17	25,4	27	42	4,5	69	M6	0,17
KF-525 D	230	51,5	242	26	26	27	42,5	47	64,5	7,0	69	M6	0,47
KF-527 D	230	60	258	35	26	29,9	42,5	46,9	72	7,0	69	M6	0,6
KF-528 D	240	70,8	305	41	42	41	62	63,5	93	8,5	69	M8	1,03

GRAMPOS TENSORES

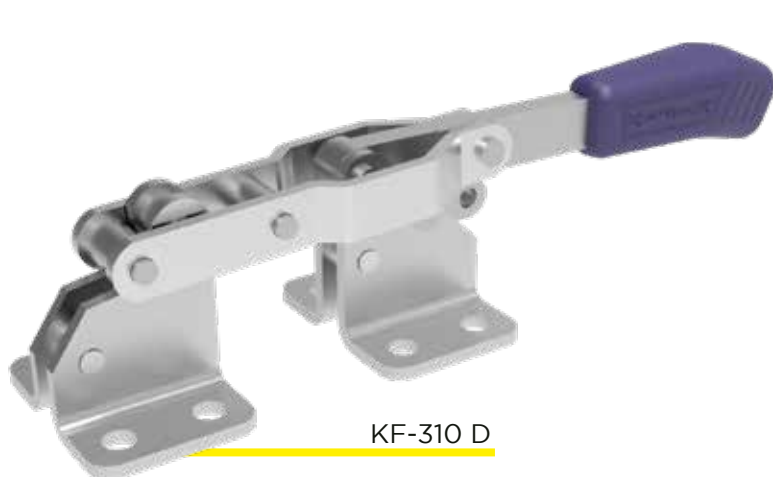

KF-310 D



KF-320

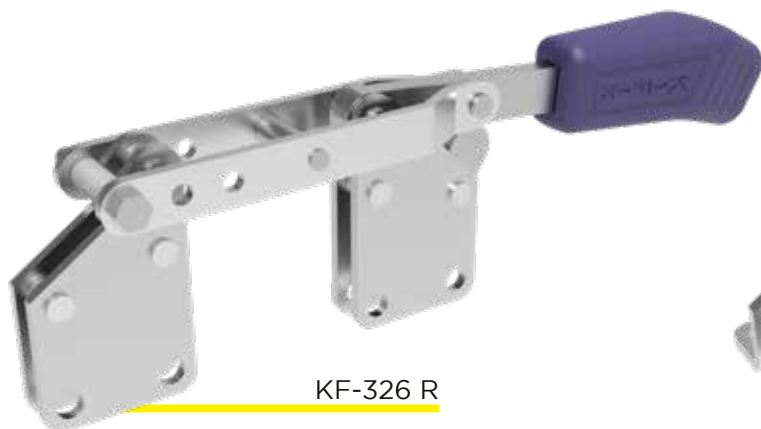

KF-326 R

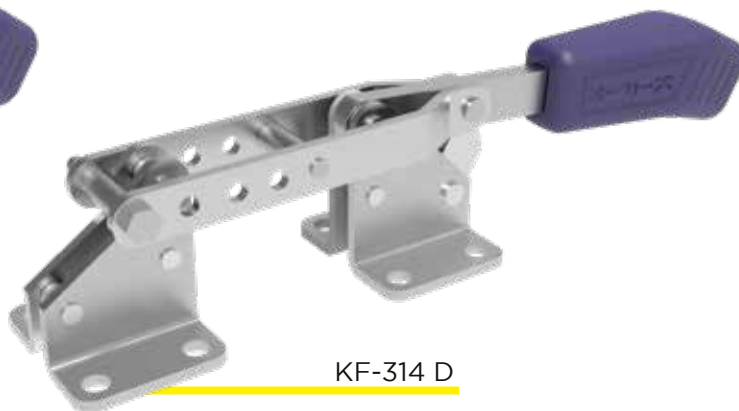

KF-314 D

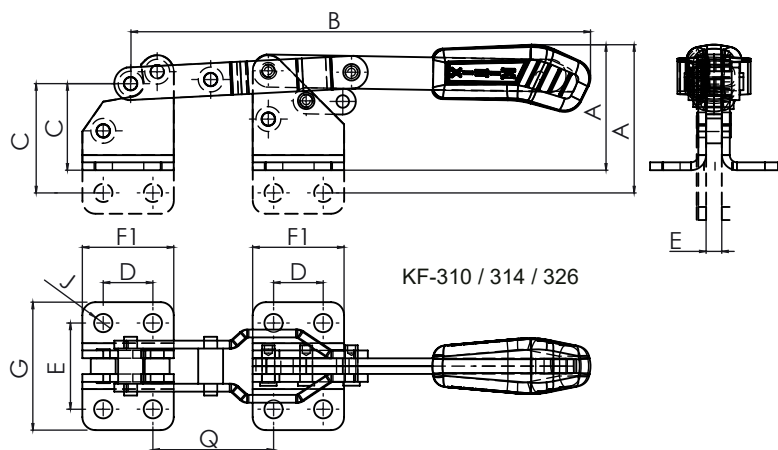

KF-310 / 314 / 326

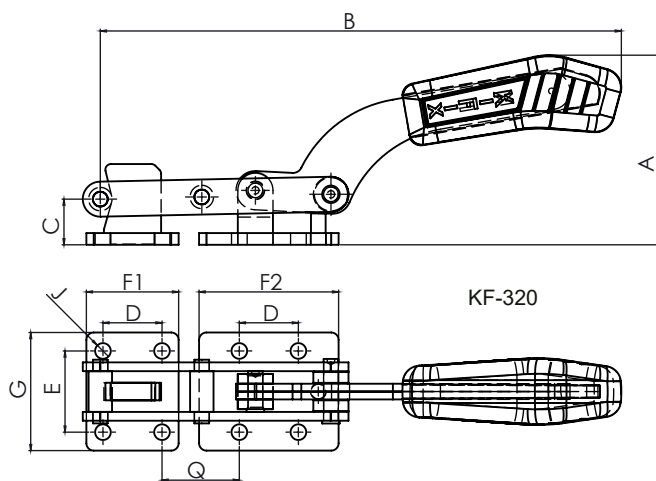

KF-320

BASES
D - Dobrada
R - Reta

REFERÊNCIA	FORÇA DE RETENÇÃO KGF	A	B	C	D	E	F1	F2	G	J	Q	BITOLA DA HASTE	PESO KG
KF-310 D	170	48	176	33	19	33	35		49	7	46	M6	0,350
KF-310 R	170	57	176	42	19	6	35			7	46	M6	0,350
KF-314 D	340	60	263	47	32	44	48		60	8,5	74	M6	0,830
KF-314 R	340	73	263	60	32	8	48			8,5	74	M6	0,830
KF-326 D	340	60	263	47	32	44	48		60	8,5	74	M6	0,830
KF-326 R	340	73	263	60	32	8	48			8,5	74	M6	0,830
KF-320	800	103	282	25	32	44	50	76	64	8,5	42	M6	1,250

GRAMPOS TENSORES



KF-133 D TR



KF-743 R

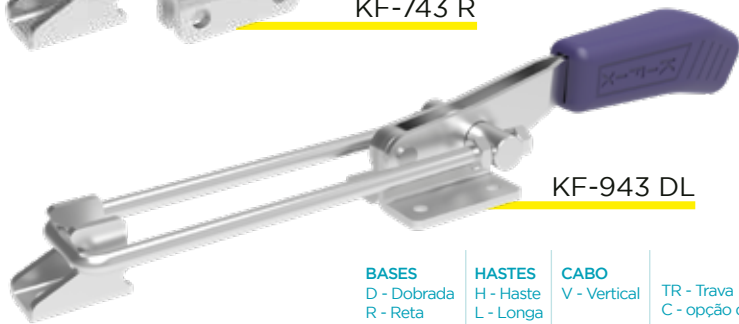

KF-943 DL

KF-943 DV

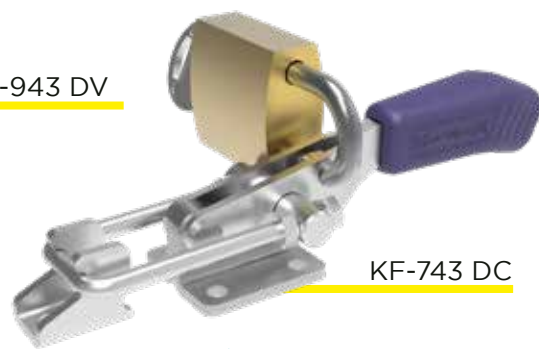

KF-743 DC

CADEADO NÃO ACOMPANHA O GRAMPO

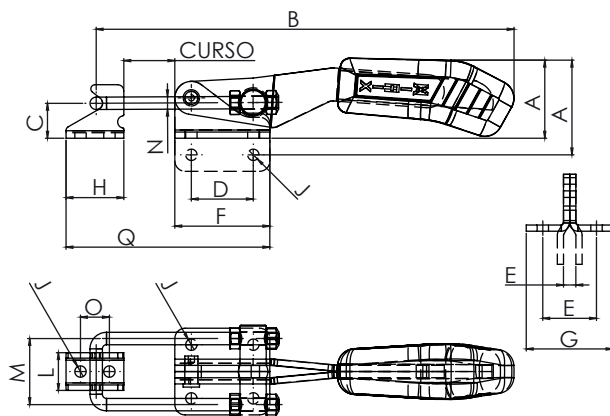

BASES
D - Dobrada
R - Retã

HASTES
H - Haste
L - Longa

CABO
V - Vertical
C - opção de cadeado

TR - Trava
C - opção de cadeado

REFERÊNCIA	FORÇA DE RETENÇÃO KGF	CURSO	A	B MIN	B MAX	C	D	E	F	G	H	J	L	M	N	O	Q MIN	Q MAX	BITOLA DA HASTE	PESO KG
KF-233 D	160	14	31	112	126	10	16	19	26	28	20	4,3	13	19	4	10	46	60	M4	0,120
KF-233 R	160	14	40	112	126	10	16	4	26		20	4,3	13	19	4	10	46	60	M4	0,120
KF-233 D TR	160	14	37	122	136	10	16	19	26	28	20	4,3	13	19	4	10	46	60	M4	0,140
KF-643 D	200	16	56	139	155	14	24	22	36	33	23	5,5	16	25	5	11	59	75	M5	0,230
KF-643 DV	200	16	121	73	89	14	24	22	36	33	23	5,5	16	25	5	11	59	75	M5	0,215
KF-643 DL	200	71	56	139	210	14	24	22	36	33	23	5,5	16	25	5	11	59	130	M5	0,240
KF-643 R	200	16	62	139	155	14	24	6	36		23	5,5	16	25	5	11	59	75	M5	0,230
KF-643 RL	200	71	62	139	210	14	24	6	36		23	5,5	16	25	5	11	59	130	M5	0,240
KF-643 D TR	200	16	59	139	155	14	24	22	36	33	23	5,5	16	25	5	11	74	90	M5	0,290
KF-743 D	200	16	37	137	153	14	24	22	36	33	23	5,5	16	25	5	11	59	75	M6	0,210
KF-743 DL	200	70	37	137	208	14	24	22	36	33	23	5,5	16	25	5	11	59	130	M6	0,220
KF-743 DC	200	16	37	137	153	14	24	22	36	33	23	5,5	16	25	5	11	59	75	M6	0,200
KF-743 R	200	16	42	137	153	14	24	6	36		23	5,5	16	25	5	11	59	75	M6	0,210
KF-743 RL	200	70	42	137	208	14	24	6	36		23	5,5	16	25	5	11	59	130	M6	0,220
KF-133 D	300	22	54	196	223	13	19	32	40	44	28	7,0	23	31	6	14	68	95	M6	0,440
KF-133 D TR	300	18	57	196	223	13	19	32	40	44	28	7,0	23	31	6	14	68	95	M6	0,530
KF-843 D	340	25	38	177	202	17	30	26	46	42	28	5,5	19	32	6	14	74	99	M6	0,360
KF-843 DL	340	126	37	177	290	17	30	26	46	42	28	5,5	18	31	6	30	74	180	M6	0,400
KF-843 DC	340	25	38	177	202	17	30	26	46	42	28	5,5	19	32	6	14	74	99	M6	0,400
KF-843 R	340	25	55	177	202	17	30	6	46		28	5,5	19	32	6	14	74	99	M6	0,360
KF-843 D TR	340	25	40	169	194	17	30	26	46	42	28	5,5	19	32	6	14	74	99	M6	0,420
KF-943 D	680	45	60	241	286	21	40	36	60	56	38	7,0	26	40	8	19	98	143	M8	0,790
KF-943 DC	680	45	60	241	286	21	40	36	60	56	38	7,0	26	40	8	19	98	143	M8	0,810
KF-943 DL	680	126	60	241	361	21	40	36	60	56	38	7,0	26	40	8	19	98	218	M8	0,850
KF-943 R	680	45	72	241	286	21	40	8	60		38	7,0	26	40	8	19	98	143	M8	0,790
KF-943 RL	680	126	72	241	361	21	40	8	60		38	7,0	26	40	8	19	98	218	M8	0,850
KF-943 D TR	680	45	60	241	286	21	40	36	60	56	38	7,0	26	40	8	19	98	143	M8	0,830
KF-143 D	890	126	73,4	207,4	225,4	21,3	41,3	38,1	60,5	54	38	8,5	26	40	8	19	98,6	116,6	M8	0,720
KF-143 D TR	890	18	73,4	207,4	225,4	21,3	41,3	38,1	60,5	54	38	8,5	26	40	8	19	98,6	116,6	M8	0,770
KF-943 DV	1200	45	183	98	148	21	40	36	60	56	38	7,0	26	40	8	19	93	143	M8	0,780
KF-943 SU H150	1400	58	60	254	299	16	40	36	60	56	60	7,0	56	44	10	36	13	58	M10	1,370
KF-943 SU H220	1400	130	60	304	369	15	40	36	60	56	38	7,0	9,5	44	10		161	226	M10	1,280

GRAMPOS TENSORES

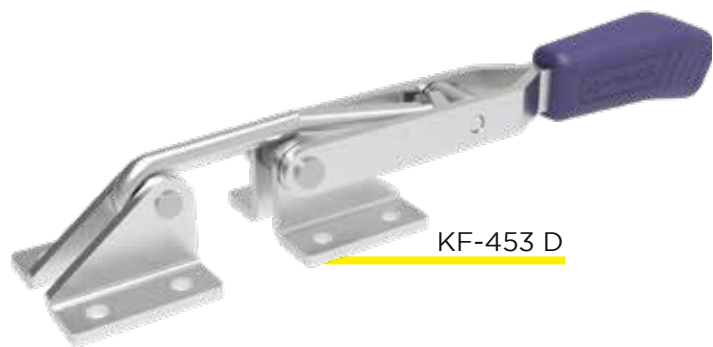

KF-453 D

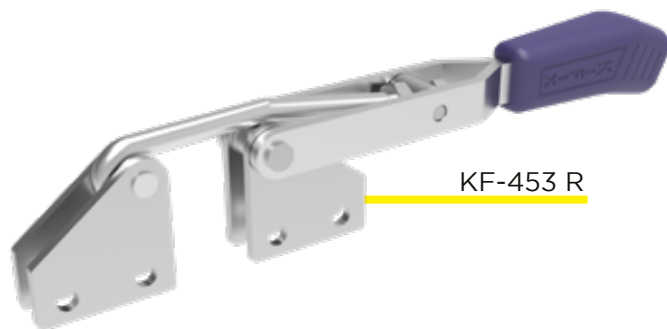

KF-453 R

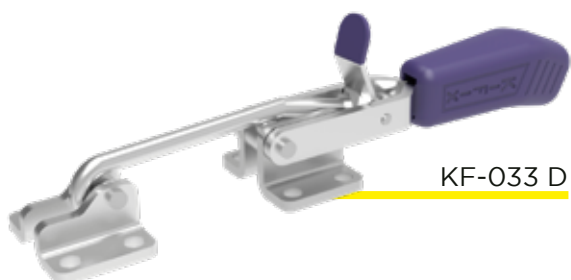

KF-033 D

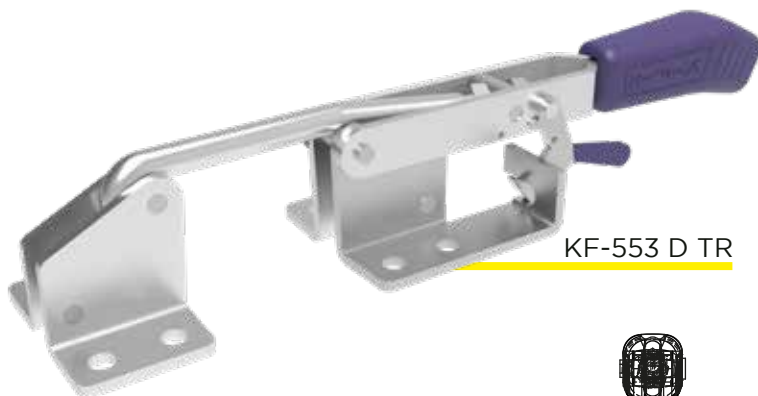

KF-553 D TR

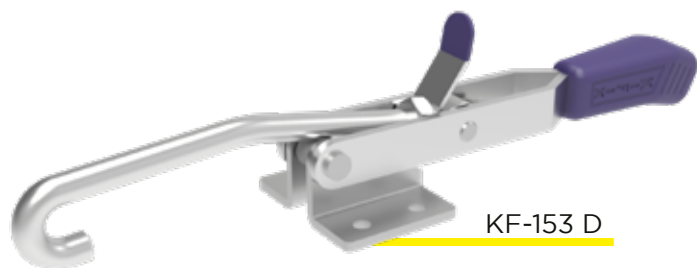

KF-153 D

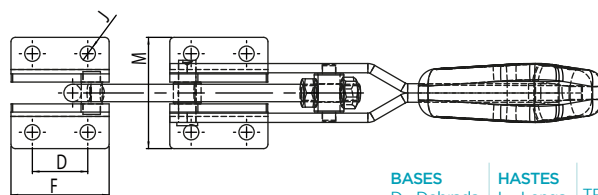
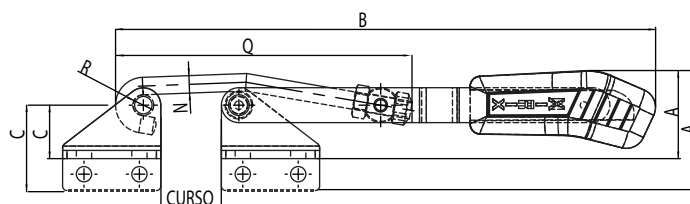
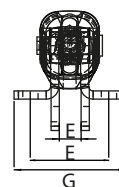

BASES
D - Dobrada
R - Reta

HASTES
L - Longa
TR - Trava

REFERÊNCIA	FORÇA DE RETENÇÃO KGF	CURSO	A	B	C	D	E	F	G	J	N	Q	R	BITOLA DA HASTE	PESO KG
KF-033 D	90	35,5	26	163	12	16	25,4	25,4	34	5,5	5,0	46	8,0	M5	0,160
KF-033 DL	65	122	30	240	12	16	25,4	25,4	34	5,5	5,0	124	8,0	M5	0,180
KF-353 D	120	15,2	35	215	18	25,4	25	35	38	5,5	6,0	40	8,0	M6	0,300
KF-353 R	120	30,2	39	215	23	25,4	6,4	35		5,5	6,0	40	8,0	M6	0,300
KF-353 D TR	120	29,2	35	215	18	25,4	25	35	38	5,5	6,0	40	8,0	M6	0,310
KF-153 D	170	58	35	241	19	19,1	35	38,1	49,3	5,5	8,0		5,0	M8	0,330
KF-153 D TR	170	58	35	251	19	19,1	35	38,1	49,3	5,5	8,0		5,0	M8	0,370
KF-153 R	170	58	44,2	265	28	19,1	8	38,1		5,5	8,0		5,0	M8	0,330
KF-453 D	340	28	40	248	25	25,4	36	45	51	7	8,0	44	10,0	M8	0,550
KF-453 R	340	28	48	248	32	25,4	10	45		7	8,0	44	10,0	M8	0,550
KF-453 D TR	340	28	40	248	25	25,4	36	45	51	7	8,0	44	10,0	M8	0,570
KF-553 D	900	76	72	367	51	28,5	60,5	54	85,5	10,6	12,0	90	10,0	M12	1,550
KF-553 R	900	76	88	367	67	28,5	13,5	54		10,6	12,0	90	10,0	M12	1,550
KF-553 D TR	900	76	72	367	51	28,5	60,5	54	85,5	10,6	12,0	90	10,0	M12	1,650

GRAMPOS TENSORES

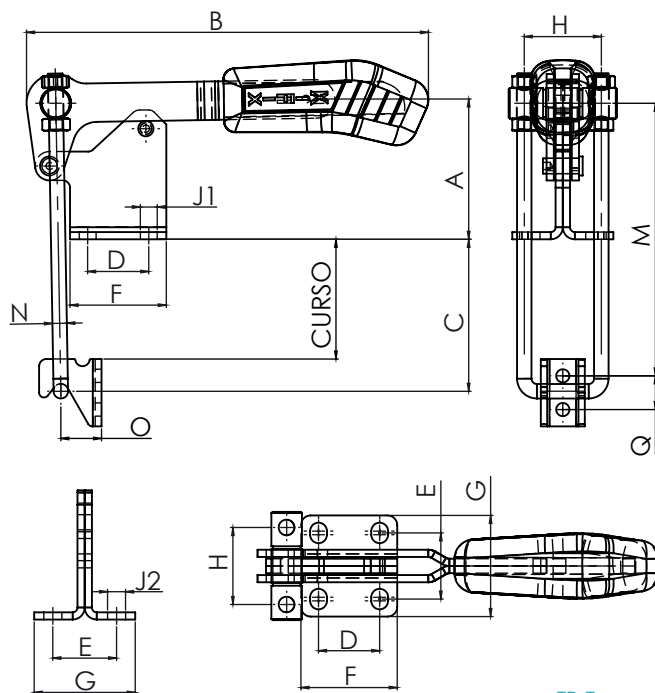

TR -Trava

REFERÊNCIA	FORÇA DE RETENÇÃO KGF	CURSO	A	B	C MAX	D	E	F	G	H	J1	J2	M MIN	M MAX	N	O	Q	BITOLA DA HASTE	PESO KG
KF-063	200	40	41	129	72	24	26	35	37,5	25	6,0	8,0	45	105	5	13	11	M5	0,250
KF-063 TR	200	40	44	137	76	24	26	35	37,5	25	6,0	8,0	45	105	5	13	11	M5	0,320
KF-163	340	50	58	167	58	25,4	27,5	40	42	32	7,0	8,5	63	108	6	16	14	M6	0,430
KF-263	680	80	52	213	78	32	33	50	55	38	8,5	12,0	67	127	8	22	19	M8	0,930
KF-263 TR	680	80	55	228	74	32	33	50	55	38	8,5	12,0	71	127	8	22	19	M8	1,090

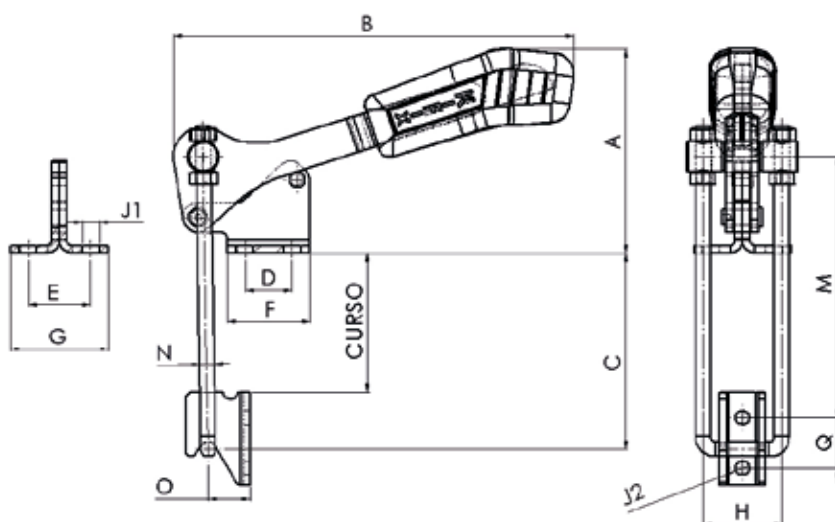

REFERÊNCIA	FORÇA DE RETENÇÃO KGF	CURSO	A	B	C MAX	D	E	F	G	H	J1	J2	M MIN	M MAX	N	O	Q	BITOLA DA HASTE	PESO KG
KF-423	220	32	77	122	83	13	22,4	25,4	35	25	5,1	4,3	35	102	5	14	14,2	M5	0,230
KF-423 D TR	220	32	77	122	83	13	22,4	25,4	35	25	5,1	4,3	35	102	5	14	14,2	M5	0,231
KF-433	450	32	84	162	80	19	25,4	33,3	40	32	7,1	5,6	50	107	6	17	20,6	M6	0,400
KF-443	890	32	93	194	88	32	36,6	49,3	54	38	8,6	8,6	65	119	8	21	27	M8	0,890

GRAMPOS TENSORES



KF-473 D

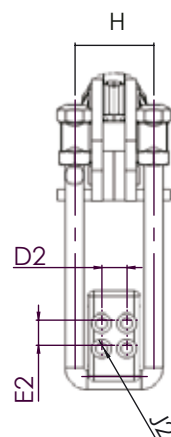
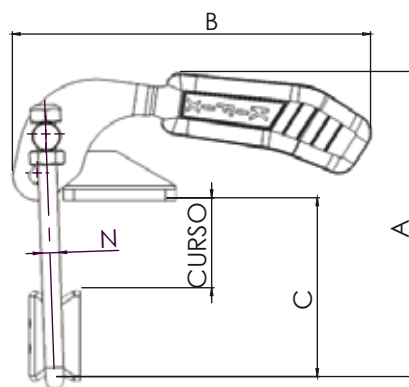
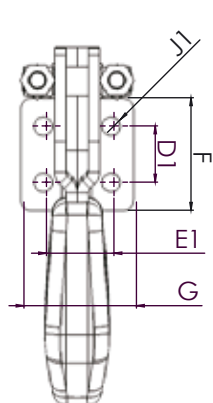

D - Dobrada

REFERÊNCIA	FORÇA DE RETENÇÃO KGF	CURSO	A	B	C	D1	D2	E1	E2	F	G	H	J1	J2	N	BITOLA DA HASTE	PESO KG
KF-473 D	1800	44	172	202	101	31,8	14,2	38,1	14,2	63,5	63,5	44,5	10,3	6,4	10	M10	1,500

KF-330

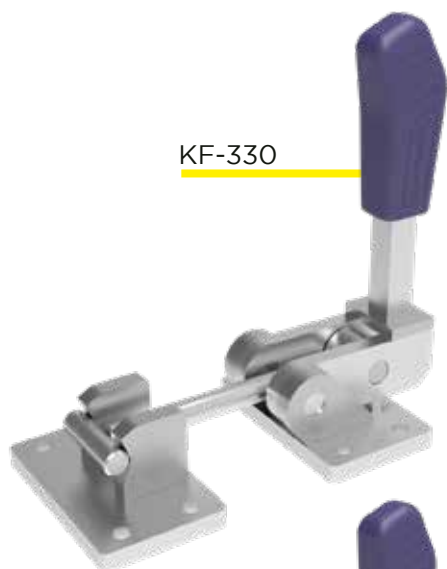

KF-340

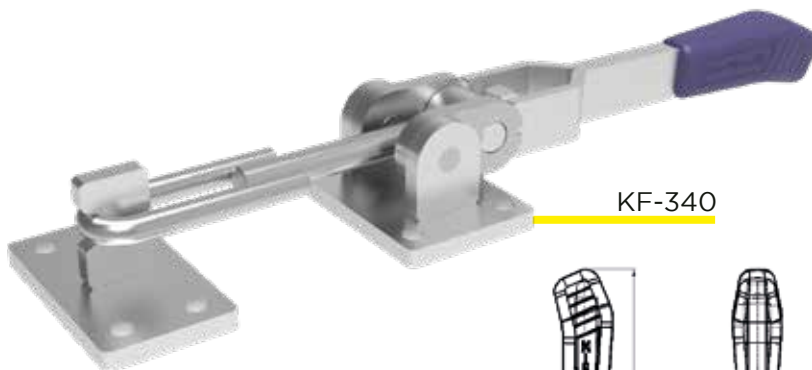

KF-350

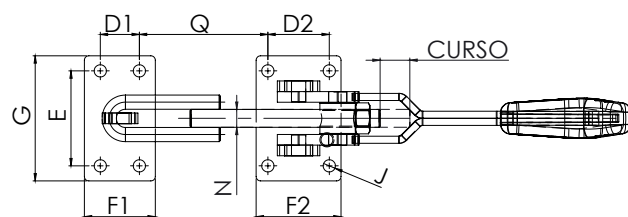
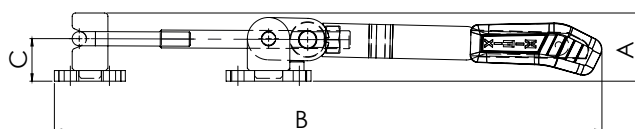
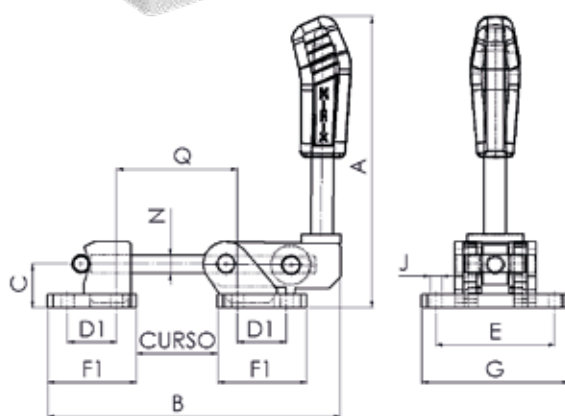

REFERÊNCIA	FORÇA DE RETENÇÃO KGF	CURSO	A	B MAX	C	D1	D2	E	F1	F2	G	J	N	PONTEIRA	Q	PESO KG
KF-330	1500	48	208	209	31	35		85	63,5		105	8,5	12,7	M16	86	2,960
KF-350	1800	50	246	239	44	35		94	60		120	11	16	M16	80	3,970
KF-340	2500	53	61	490	38,1	35	55	85	63,5	76	112	11	16	M16	115	3,200

GRAMPOS TENSORES



KF-385

KF-375 TR

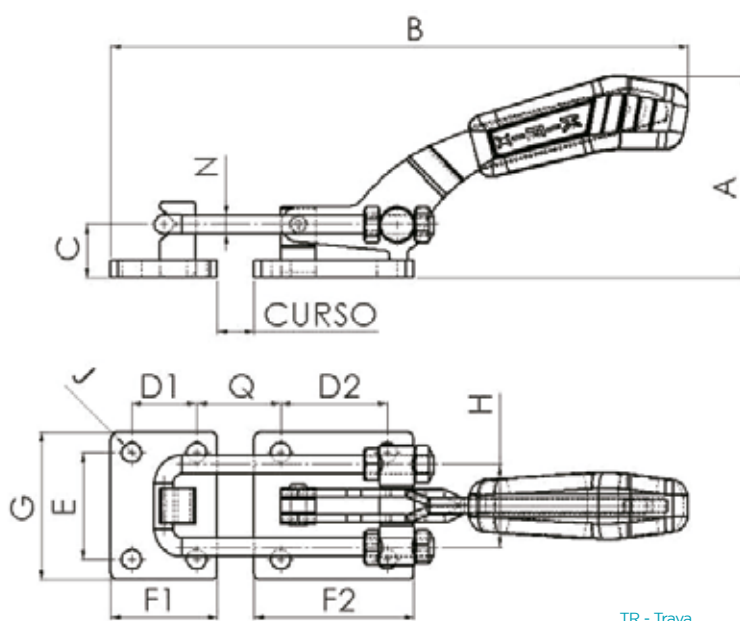

TR - Trava

REFERÊNCIA	FORÇA DE RETENÇÃO KGF	CURSO	A	B MAX	C	D1	D2	E	F1	F2	G	H	J	N	Q	BITOLA DA HASTE	PESO KG
KF-375	1500	20	109	310	29	35	57,2	57,2	57	86	80	45	10,5	10	45	M10	1,800
KF-375 TR	1500	20	117	326	29	35	57,2	57,2	57	86	80	45	10,5	10	45	M10	2,140
KF-385	3400	26	106	310	29	35	57,2	57,2	57	86	80	54	10,5	12	50	M12	2,200
KF-385 TR	3400	26	110	335	29	35	57,2	57,5	57	86	80	54	10,5	12	50	M12	2,500

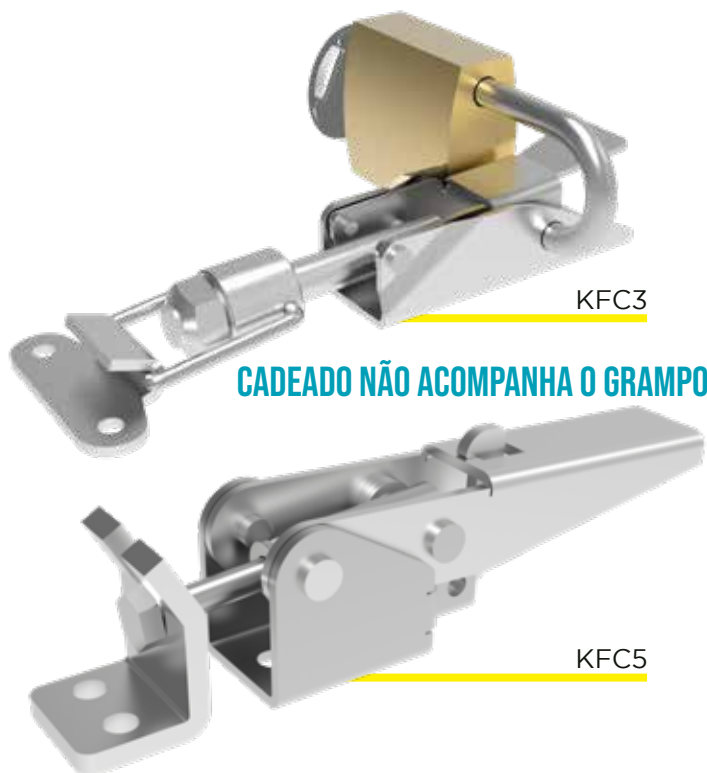

KFC3

CADEADO NÃO ACOMPANHA O GRAMPO

KFC5

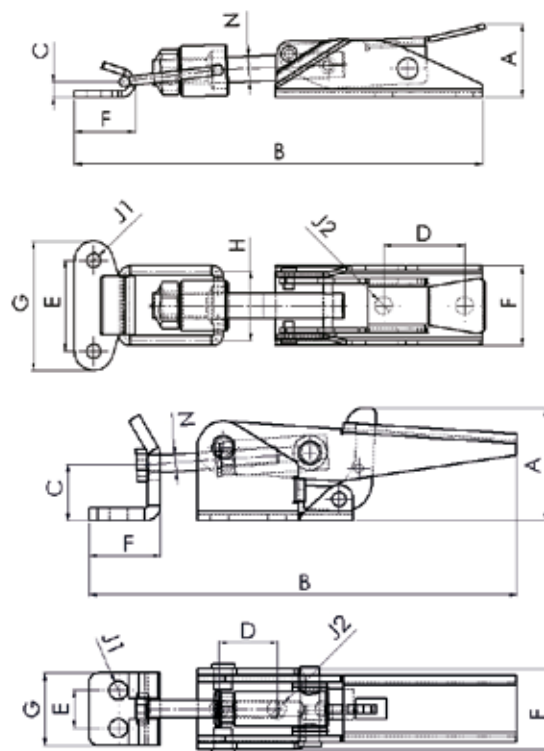

REFERÊNCIA	FORÇA DE RETENÇÃO KGF	CURSO	A	B	C	D	E	F	G	H	J1	J2	N	PESO KG
KFC3	3	24	23	128	5	25,5	28,5	19	40,5	22	4,4	5,5	8	0,130
KFC4	100	27	18,4	67	13	8	14,3	26	25,5	0	4,2	4,2	4	0,53
KFC5	180	60	38,9	148	17,5	20	13	24,5	25	0	6,4	6,4	6	0,235

GRAMPO TENSOR COM CINTA



KF-233 CT 50



KF-743 CT 200



KF-843 CT 300

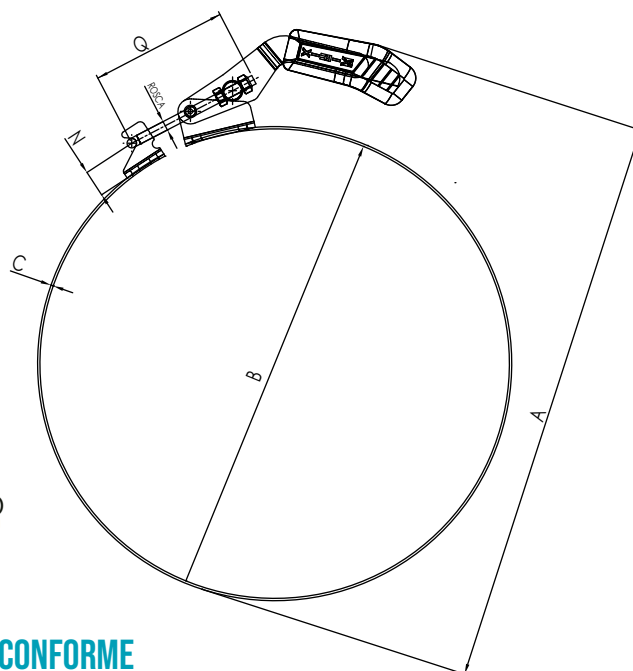
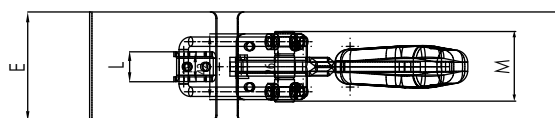

**CINTA PRODUZIDA CONFORME
A NECESSIDADE DO CLIENTE**

DISPONÍVEL NOS GRAMPOS TENSORES: KF-233 | KF-743 | KF-843 - PÁG 26

CT - Cinta

EXEMPLO:

REFERÊNCIA	FORÇA DE RETENÇÃO KGF	CURSO	A	B	C	E	L	M	N	Q	BITOLA DA HASTE	PESO KG
KF-233 CT 50	160	14	100	50	1,5	25	4,3	19	4	53	M4	0,153
KF-743 CT 200	200	16	236	200	1,5	30	6,35	25	5	65	M5	0,390
KF-843 CT 300	200	16	365	200	1,5	70	19	70	6	90	M6	1,145

GRAMPOS TORPEDOS

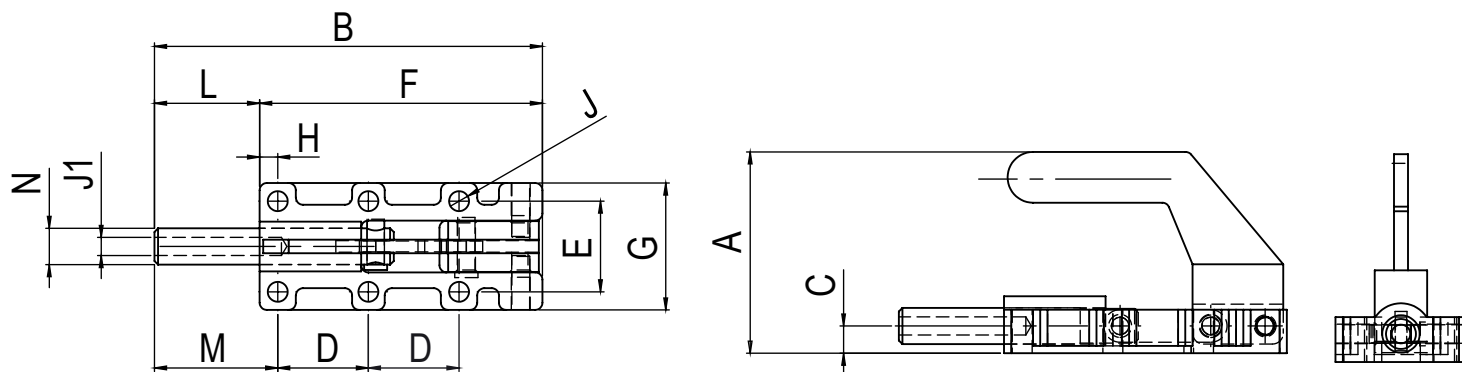
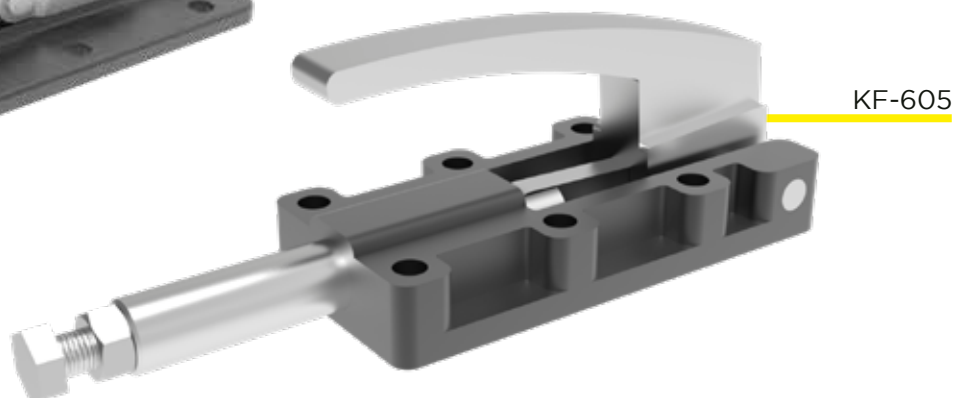
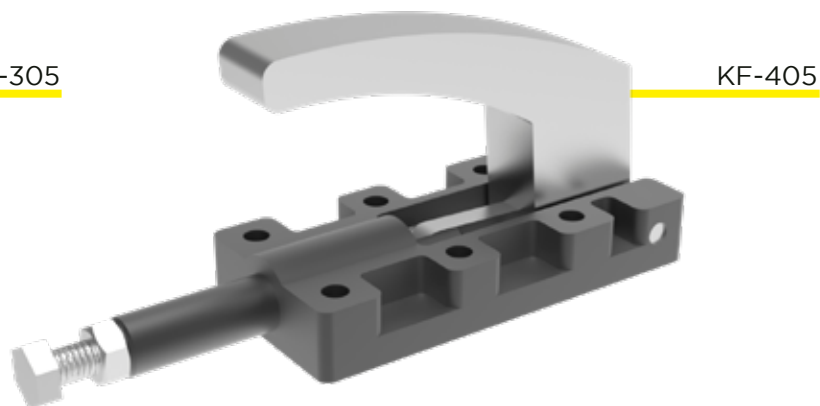
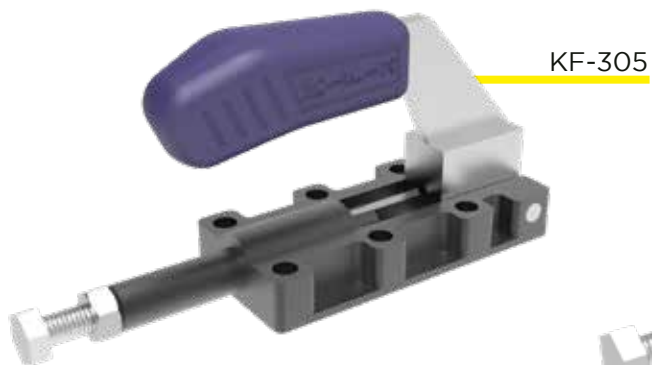

REFERÊNCIA	FORÇA DE RETENÇÃO KGF	CURSO	A	B	C	D	E	F	G	H	J	J1	L	M	N	PONTEIRA	PESO KG
KF-305	250	25	60	105	7,5	25	25	78	35	5	5,5	M6X1,00	26,5	32	10	M6	0,350
KF-405	500	35	73	148	10	35	35	111	51	8,5	6,5	M8X1,25	37	46	14	M8	1,100
KF-505	750	50	78	190	14	45	45	141	66	10	8,5	M12X1,75	50	60	19	M12	1,820
KF-605	1200	60	84	238	16	55	55	171	76	10	10,5	M12X1,75	67	77	22	M12	2,870
KF-067	1500	41,5	97	152	17,5	35	41	108	55	16	7,0	M8X1,25	43	61	12	M8	0,676

GRAMPOS TORPEDOS



KF-057 TR



KF-061

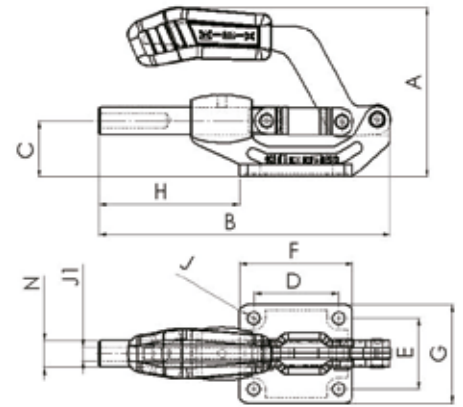

KF-051



KF-053

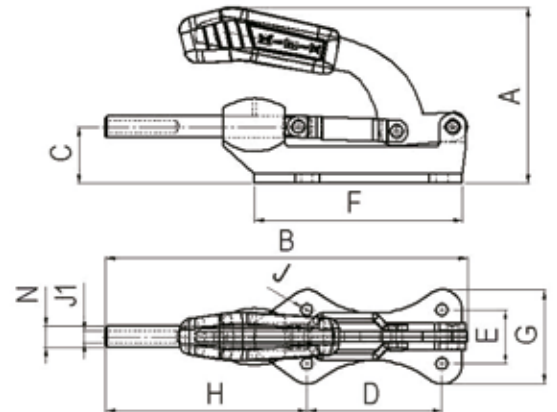

KF-052 IV

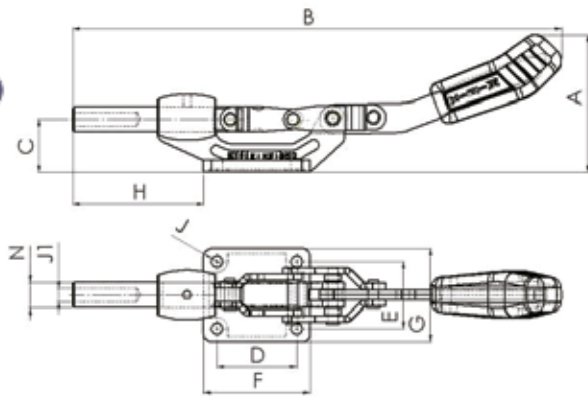

TR - Trava
IV - Ação Invertida
RF - Base Reforçada

REFERÊNCIA	FORÇA DE RETENÇÃO KGF	CURSO	A	B	C	D	E	F	G	H	J	J1	N	PONTEIRA	PESO KG
KF-061	50	16	51,3	66,1	13,7	16	16	35,4	26,7	22,5	4,3	M4X0,70	6,35	M4	0,070
KF-057	230	36	82	144	25	35	40	50	55	71	7,0	M8X1,25	12	M8	0,400
KF-057 TR	230	36	98	144	25	35	40	50	55	71	7,0	M8X1,25	12	M8	0,420
KF-057 IV	230	35	34	239	25	35	40	50	55	71	7,0	M8X1,25	12	M8	0,395
KF-051	270	35	92,2	125	24,8	36,6	33,3	58	48	57	6,3	M8X1,25	12	M8	0,390
KF-054	380	41	107,9	154	31,8	41,4	41,4	58,7	57,2	42,2	8,5	M10X1,50	16	M10	0,890
KF-054 IV	380	46	57,2	339	31,8	41,4	41,4	158	57,2	81	8,5	M10X1,50	16	M10	0,930
KF-053	500	83	127	268	42	100	40	154	70	149	8,5	M10X1,50	16	M10	2,150
KF-053 TR	500	83	134	268	42	100	40	154	70	149	8,5	M10X1,50	16	M12	2,220
KF-052	700	50	116	205	40	60	50	80	70	99	8,5	M12X1,75	19	M12	1,280
KF-052 TR	700	50	137	205	40	60	50	80	70	99	8,5	M12X1,75	19	M12	1,710
KF-052 IV	700	52	103	368	40	60	50	80	70	98	8,5	M12X1,75	19	M12	1,590
KF-052 RF	1200	50	120	205	40	60	50	80	70	99	8,5	M12X1,75	19	M16	1,660
KF-056	1800	78	150	287	57	100	60	162	86	162	10,5	M16X2,00	25	M16	3,500

GRAMPOS TORPEDOS COM ALÇA



KF-025 AL



KF-054 AL



KF-052 AL

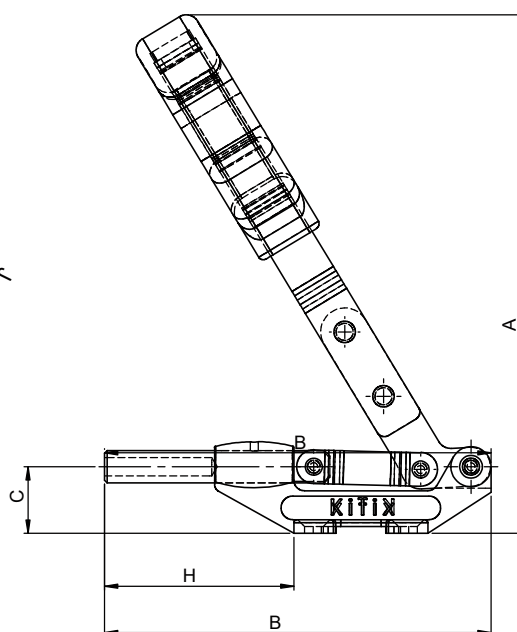
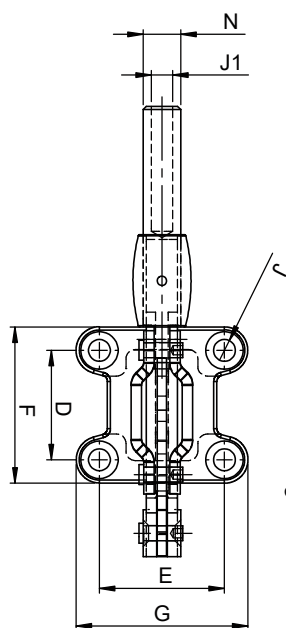
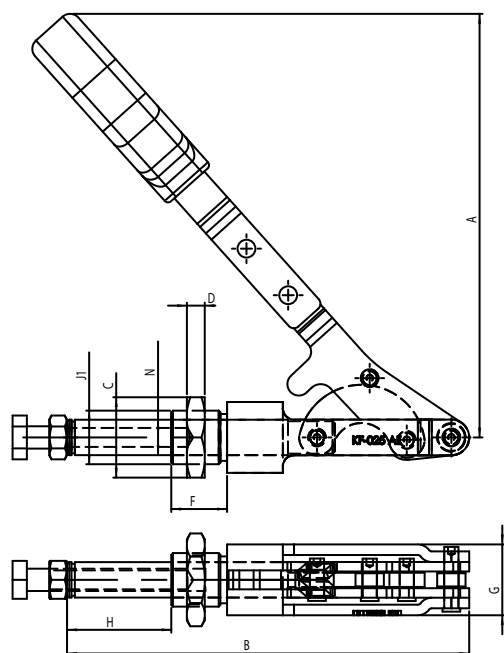

AL - Alça

REFERÊNCIA	FORÇA DE RETENÇÃO KGF	CURSO	A	B	C	D	E	F	G	H	J	J1	N	PONTEIRA	PESO
KF-057 AL	230	36	193	144	25	35	40	50	55	71	7	M8X125	12	M8	0,82
KF-056 AL	250	79	206	287	57	100	60	154	86	162	10,5	M16X2,0	25	M16	3,52
KF-054 AL	380	41	196	154	40	414	414	58,7	572	422	8,5	M10 X150	16	M10	1,20 5
KF-053 AL	500	87	180	264	42	100	40	154	70	149	8,5	M10 X150	16	M10	2,16
KF-025 AL	500	46	190	180	36	8		25	3175	47		M24X2,00	16	M10	1,30 7
KF-052 AL	700	50	215	205	40	60	50	80	70	99	8,5	M12X175	19	M12	1,55

GRAMPO TORPEDO COM GIRO

COM OPÇÃO DE GIRO PARA A DIREITA E PARA A ESQUERDA

KF-007 G

Vista superior



Vista lateral

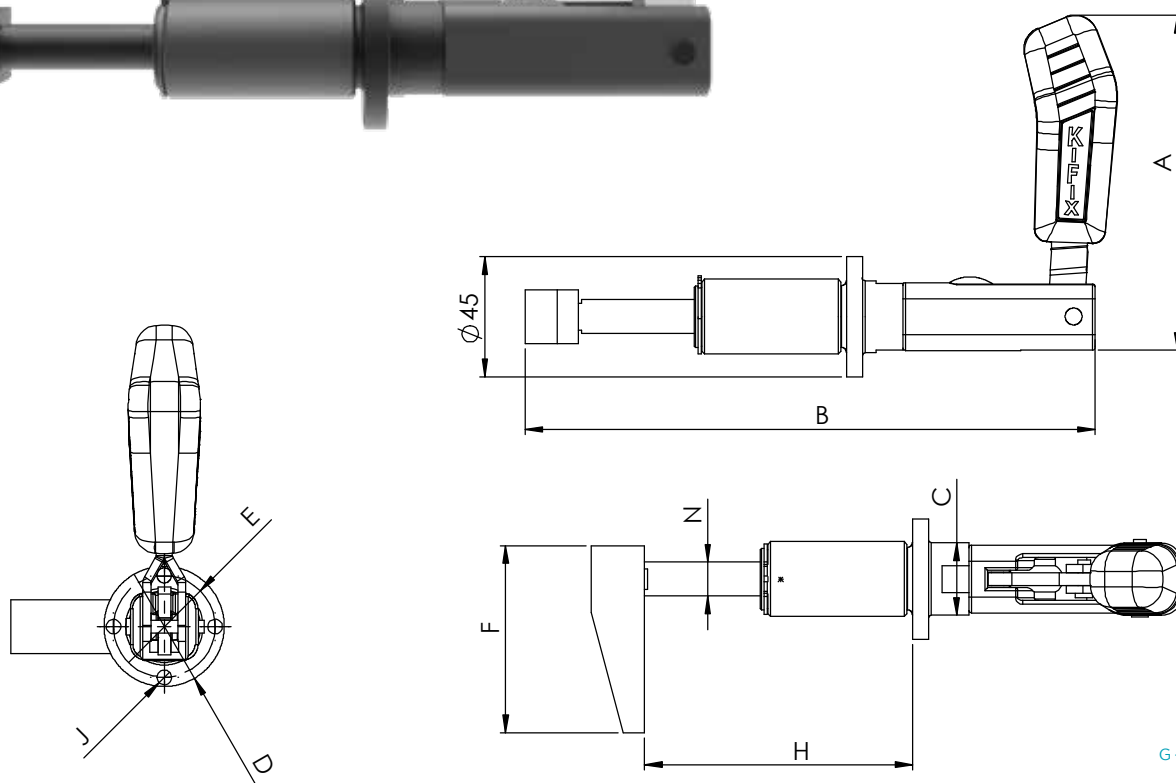

G - Giro

REFERÊNCIA	FORÇA DE RETENÇÃO KGF	CURSO	A	B	C	D	E	F	H	J	N	PESO KG
KF-007 G	200	42	125	213	27	45	38	70	100	5,5	12,7	0,925

GRAMPOS TORPEDOS FRONTAIS

KF-005



KF-006



KF-007 TR



KF-025 L



KF-015 TR

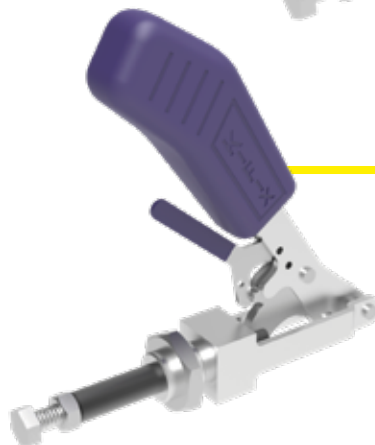

KF-035

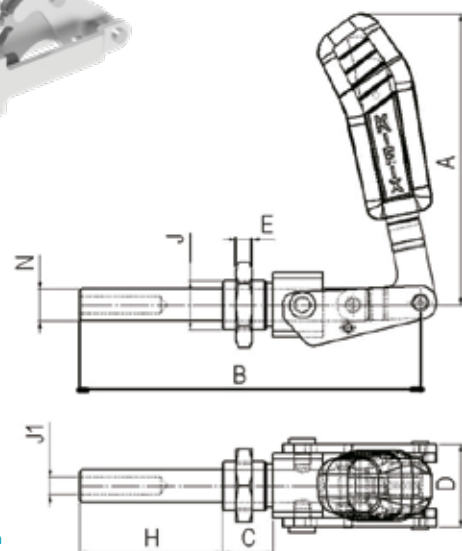

HASTES
L - Longa
IV - Invetida

TR - Trava | A - Aberta

REFERÊNCIA	FORÇA DE RETENÇÃO KGF	CURSO	A	B	C	D	E	H	J	J1	N	PONTEIRA	PESO KG
KF-005	90	20	79	60	12	26	6	21	M16X1,50	M6X1,00	9,5	M6	0,190
KF-006	120	39	107	105	16,5	31	7	39	M20X1,50	M8X1,25	12	M8	0,420
KF-009	150	60	109	138	16,5	31	7	62	M20X1,50	M8X1,25	12	M8	0,460
KF-007	200	41	125	125	18	25,4	7	42	M20X1,50	M8X1,25	12,7	M8	0,490
KF-007 TR	200	41	135	125	18	25,4	7	42	M20X1,50	M8X1,25	12,7	M8	0,515
KF-007 TR A	200	41	135	125	18	25,4	7	43	M20X1,50	M8X1,25	12,7	M8	0,508
KF-015	250	34	115	137	20	25	8,5	35	M20X1,50	M8X1,25	12	M8	0,470
KF-015 TR	250	34	142	137	20	25	8,5	35	M20X1,50	M8X1,25	12	M8	0,540
KF-015 IV	250	34	125	142	20	25	8,5	35	M20X1,50	M8X1,50	12	M8	0,460
KF-015 F 90	250	35	180	142	20	25	7	35	M20X1,50	M8X1,25	12	M8	0,570
KF-025	500	40	132	180	25	32	10	47	M24X2,00	M10X1,50	16	M10	0,990
KF-025 TR	500	40	132	180	25	32	10	47	M24X2,00	M10X1,50	16	M10	1,020
KF-025 L	300	99	151	316	25	32	10	102	M24X2,00	M10X1,50	16	M10	1,400
KF-035	320	66	143	175	25	40	10	70	M24X2,00	M10X1,50	16	M10	0,920
KF-035 TR	320	66	143	175	25	40	10	70	M24X2,00	M10X1,50	16	M10	0,980

GRAMPOS TORPEDOS FRONTAIS

KF-025/035
BASE L

KF-006/007/015
BASE L

KF-005
BASE L

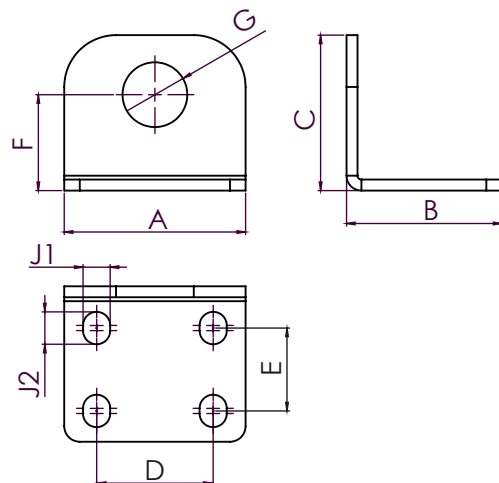
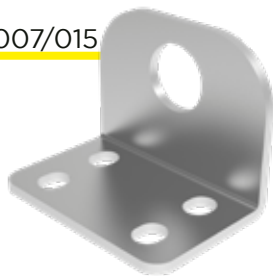
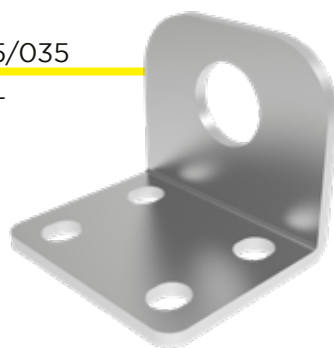

REFERÊNCIA	A	B	C	D	E	F	G	J1	J2	PESO KG
KF-005 BASE L	60	40	40	40	16	24	16,5	8,5	8,5	0,075
KF-006/007/015 BASE L	65	44	50	40	20	33	20,5	8,5	10,5	0,140
KF-025/035 BASE L	70	60	60	45	32	37	25	10,5	12,5	0,250

GRAMPOS TORPEDOS COM HASTE QUADRADA

KFKT-012

KFKT-012 F

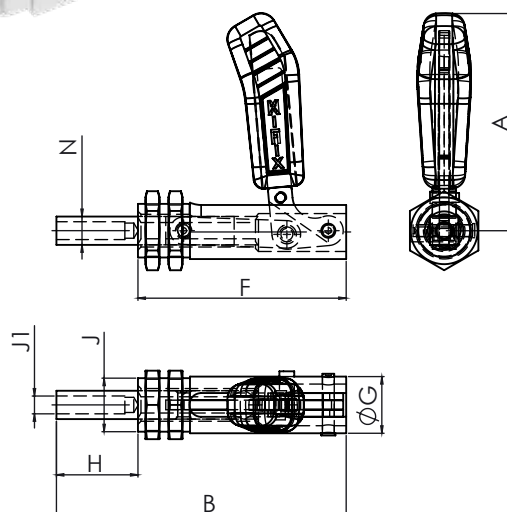
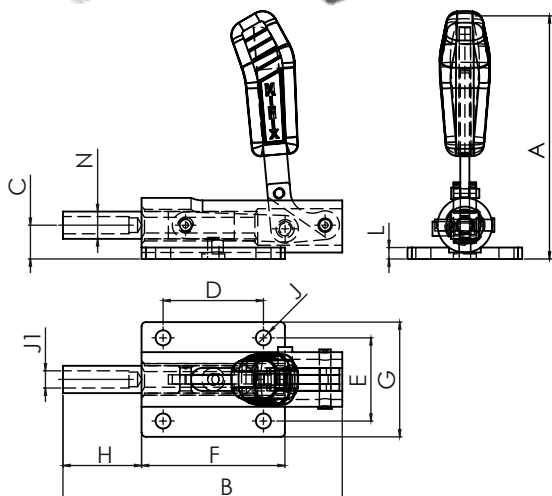

BASES
F - Frontal

REFERÊNCIA	FORÇA DE RETENÇÃO KGF	CURSO	A	B	C	D	E	F	G	H	J	J1	L	N	PONTEIRA	PESO KG
KFKT-012	900	48	173	195	23,6	70	58	100	80	55	10,5	M12X1,75	8	19	M12	1,850
KFKT-012 F	900	48	146	195				140	38,1	55	M36X1,5	M12X1,75		19	M12	1,530

GRAMPOS DE FIXAÇÃO DUPLA

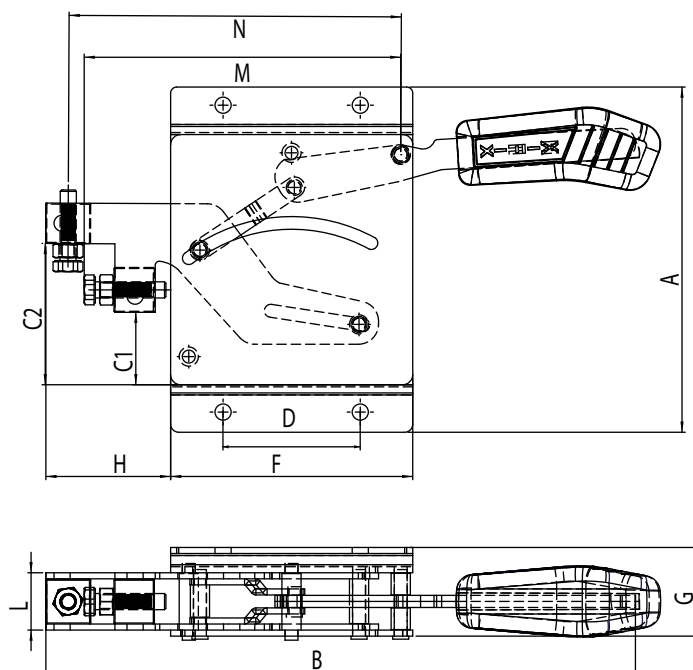
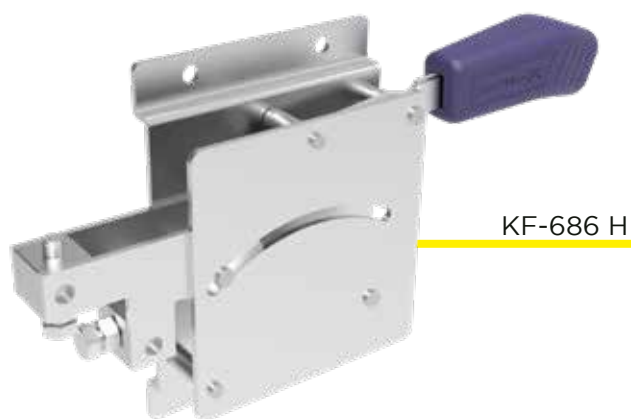
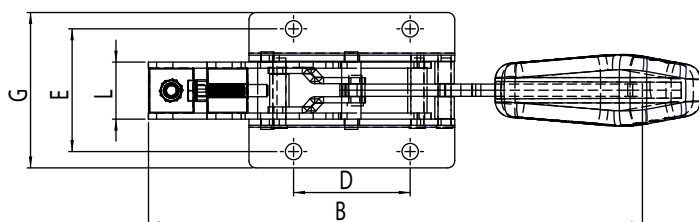
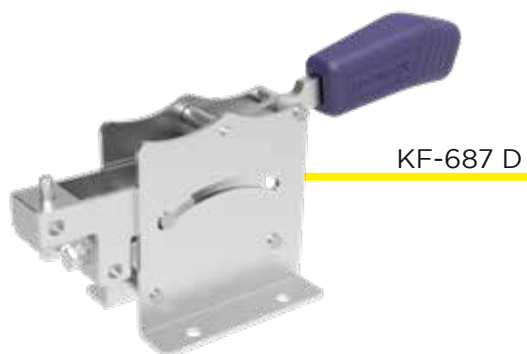
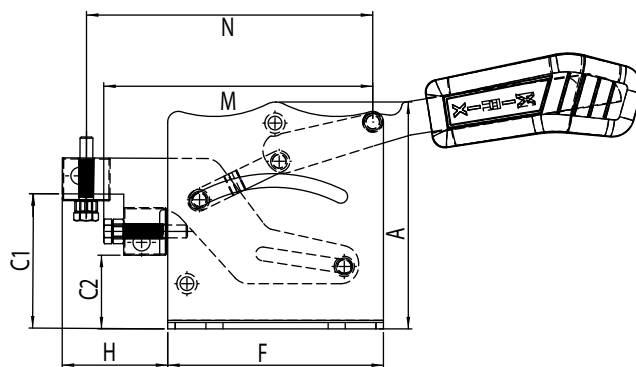
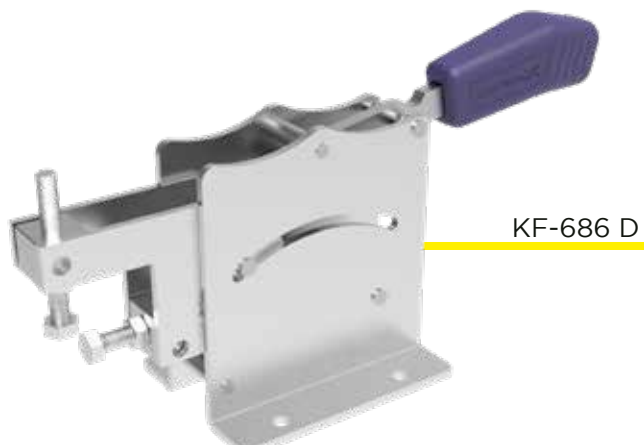

BASES
D - Dobrada
H - Horizontal

REFERÊNCIA	FORÇA DE RETENÇÃO KGF	A	B	C1	C2	D	E	F	G	H	L	M	N	PONTEIRA	PESO KG
KF-687 D	200	106	242	35	63	57	60	101	76	49	28	126	134	M8	1,18
KF-686 D	300	144	297	38	61	68	73	120	93	58	31	162	172	M8	2,18
KF-686 H	300	171	292	36	70	68	-	120	44	62	28	157	165	M8	1,59

FUSOS RÁPIDOS

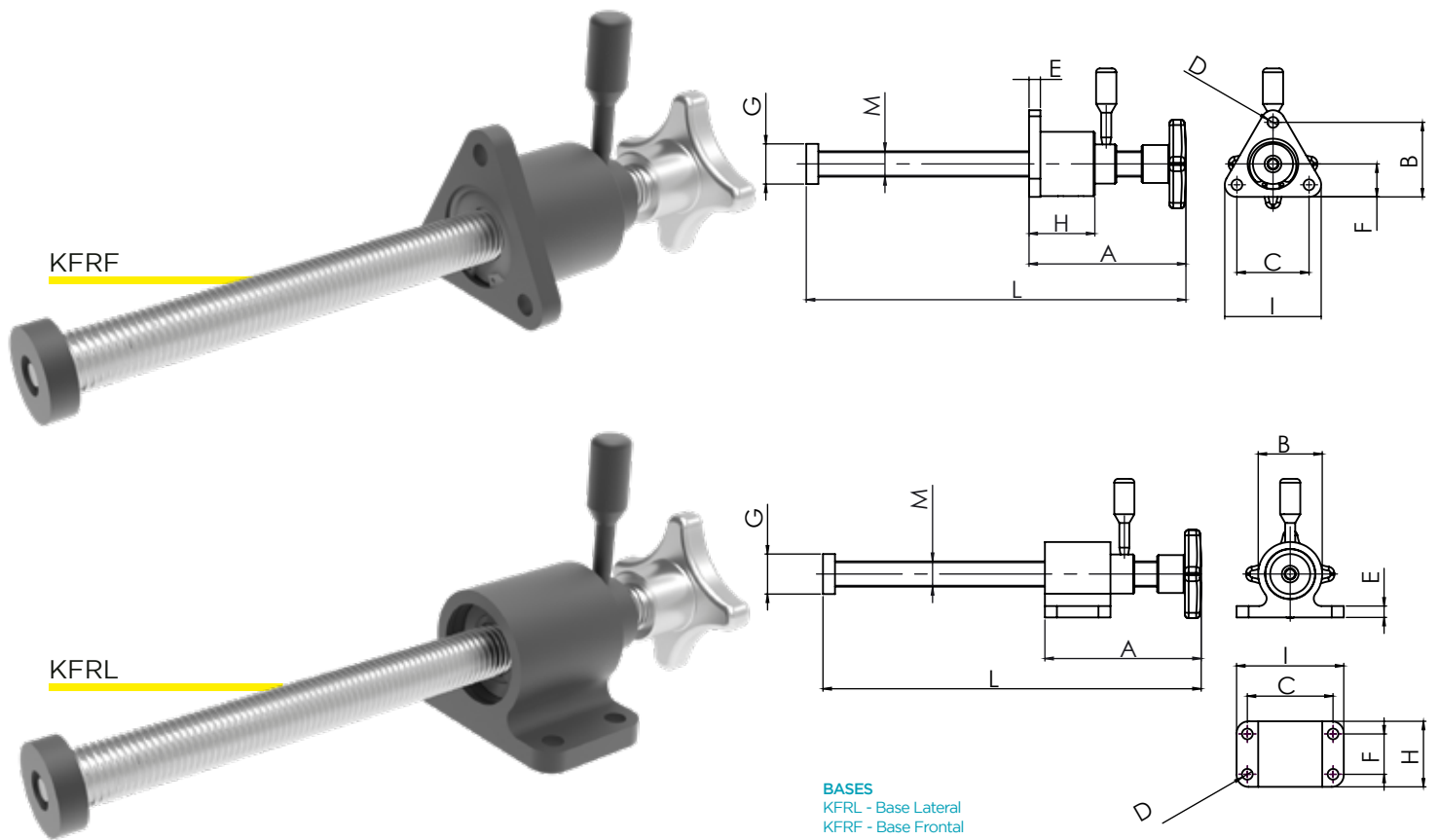

BASES
 KFRL - Base Lateral
 KFRF - Base Frontal

REFERÊNCIA	FORÇA DE RETENÇÃO KGF	A	B	C	D	E	F	G	H	I	L	M	PESO KG
KFRL-12	500	64,5	35	45	5,5	6	20	19	32	55	175,4	M12x1,75	0,48
KFRF-12	500	64,5	38,9	38	5,5	6	17	19	32	50	175,4	M12x1,75	0,42
KFRL-16	750	93,7	40	53	7	8	28	25	40	65	249	M16x2,00	0,92
KFRF-16	750	93,7	50	48,5	7	8	22	25	40	64,5	249	M16x2,00	0,82
KFRL-20	1500	116	50,8	68	8,5	9	32	32	52	85	292	M20x2,00	1,95
KFRF-20	1500	116	59	57	8,5	9	26,1	32	52	76	292	M20x2,00	1,75

MANÍPULOS

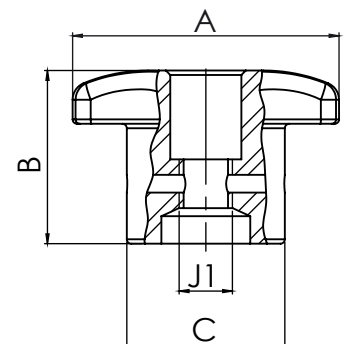
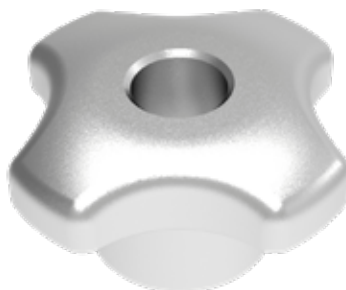

ACABAMENTOS DISPONÍVEIS:
 Zincado Branco
 Oxidado Preto

REFERÊNCIA	A	B	C	J1	PESO KG
KFM-6	30	16	16	M6x1,0	0,055
KFM-8	41	20	19,5	M8x1,25	0,105
KFM-10	48	24	22	M10x1,5	0,165
KFM-12	67	30	26	M12x1,75	0,305
KFM-16	80	45	40	M16x2,00	0,575

GRAMPOS SARGENTOS

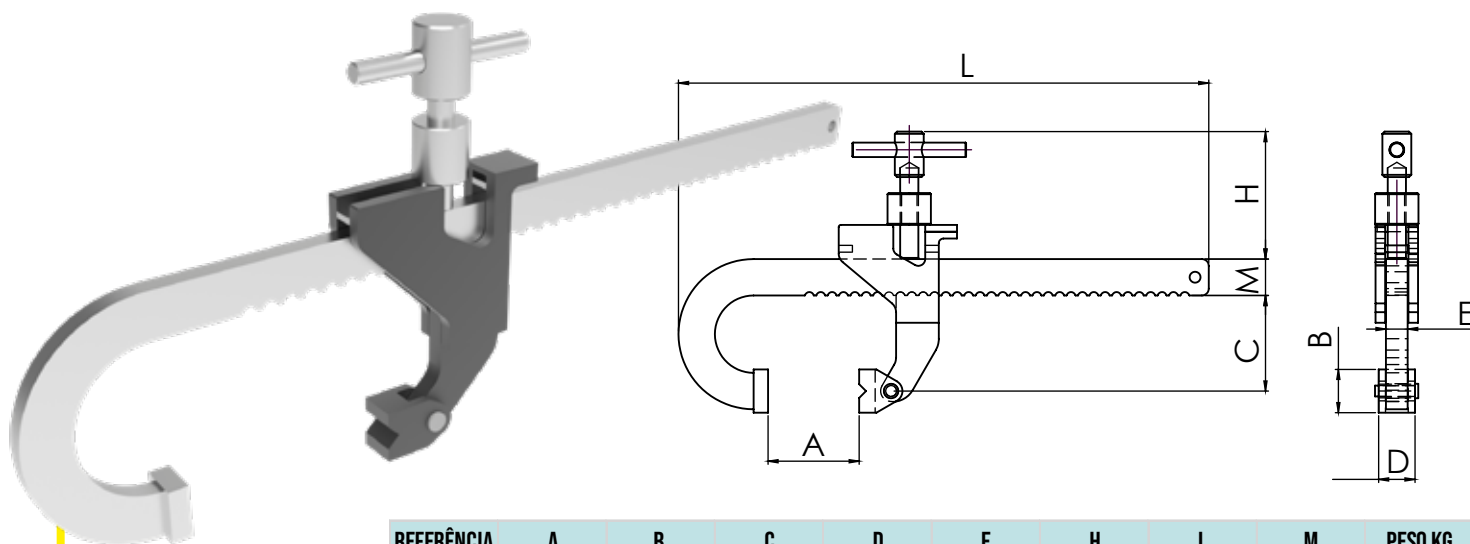

KF-150

REFERÊNCIA	A	B	C	D	E	H	L	M	PESO KG
KFS-150	150	19	42	16	9,5	50	233	16	0,600
KFS-300	320	25,4	81	19	9,5	85	472	22	1,900

GRAMPOS COMPRESSORES

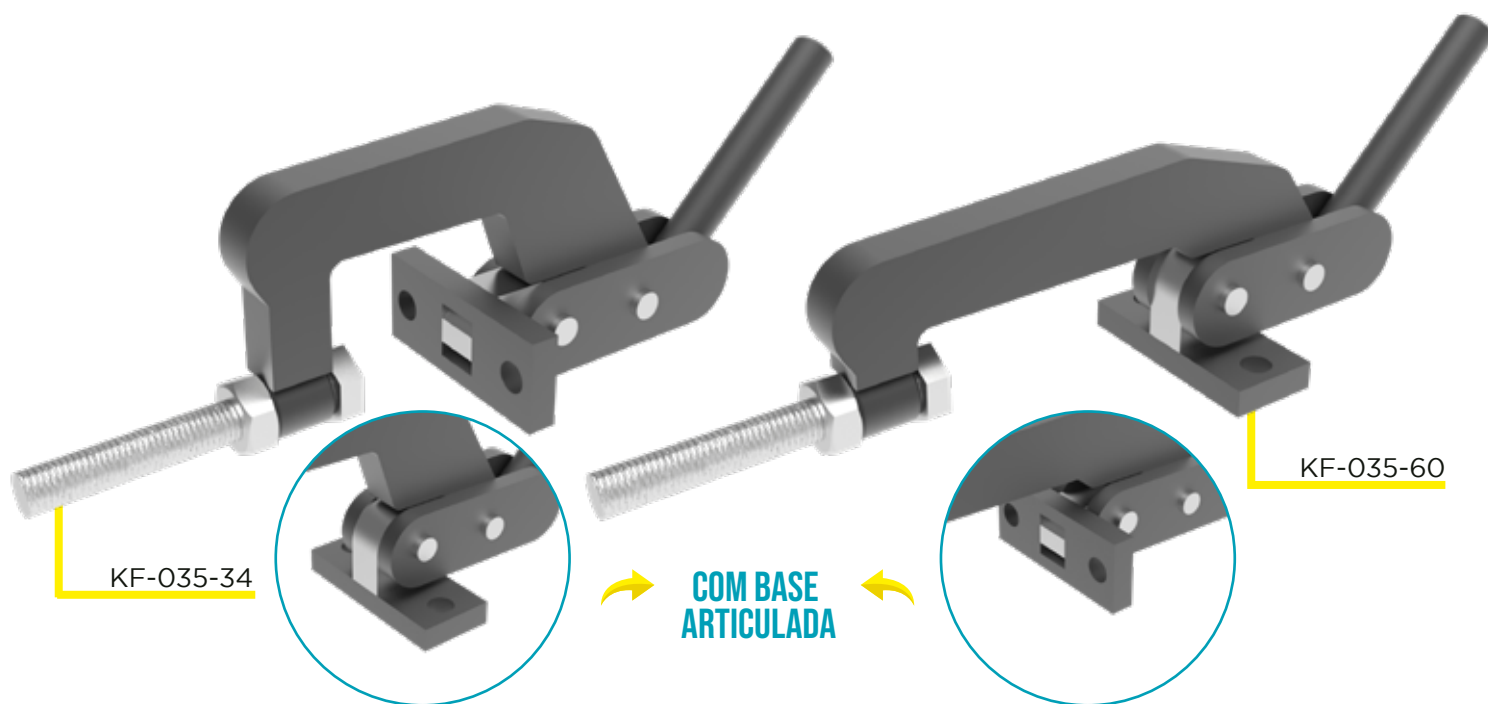

KF-035-34

KF-035-60

COM BASE ARTICULADA

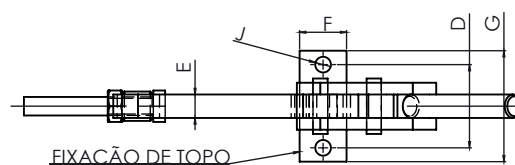
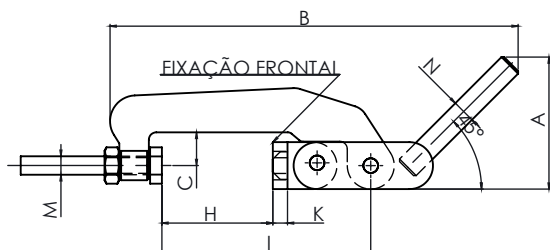

REFERÊNCIA	FORÇA DE RETENÇÃO KGF	A	B	C	D	E	F	G	H	I	J	K	M	N	PONTEIRA	PESO KG
KF-035 34	1000	71	195	36	45	12,7	25,4	60	34	87	8,5	7,94	M10	12,7	M10	0,910
KF-035 60	1000	71	221	18	45	12,7	25,4	60	60	113	8,5	7,94	M10	12,7	M10	0,890
KF-035 3660	1000	71	221	36	45	12,7	25,4	60	60	113	8,5	7,94	M10	12,7	M10	0,955
KF-035 100	2000	101	318	70	68	15,9	40	88	100	164	10,5	12,7	M10	15,9	M10	2,215

GRAMPOS PNEUMÁTICOS

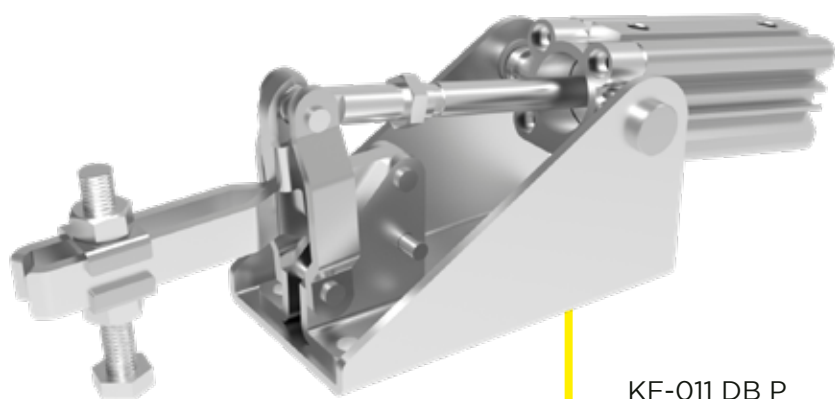

KF-011 DB P

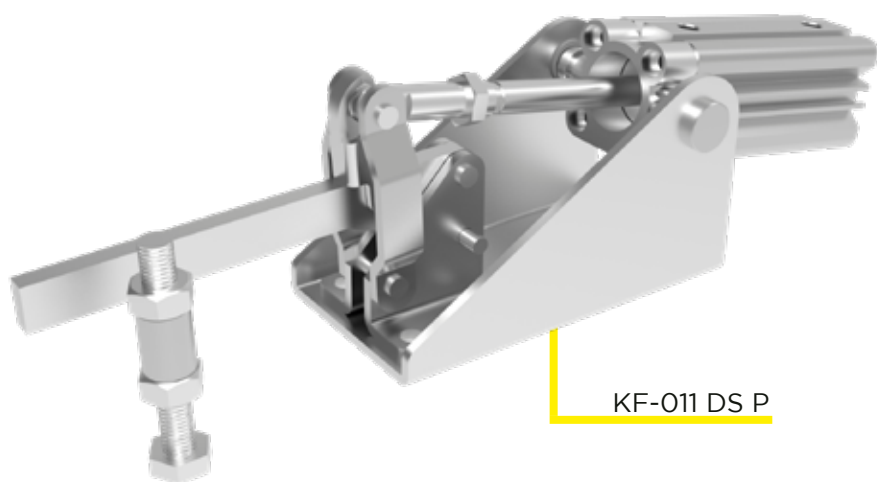
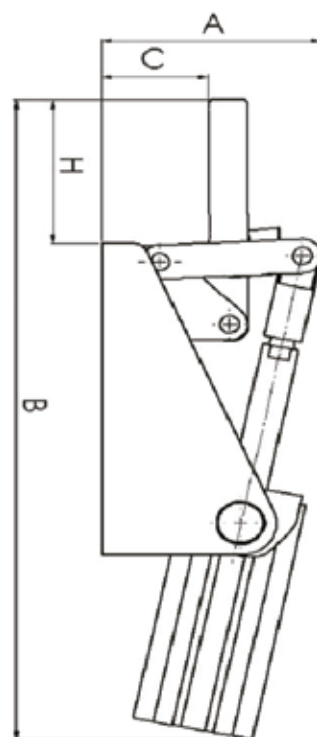

KF-011 DS P

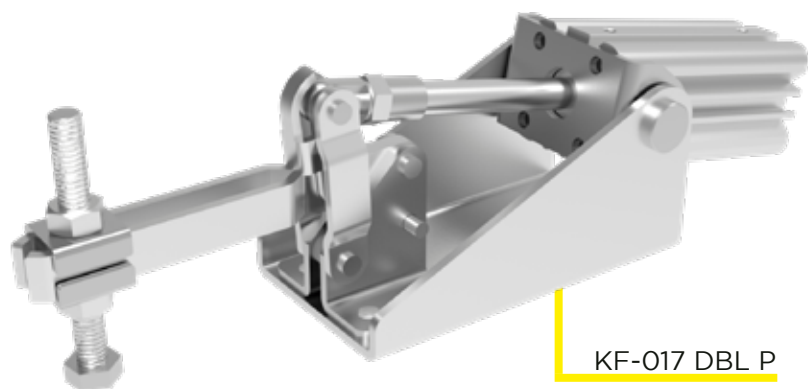
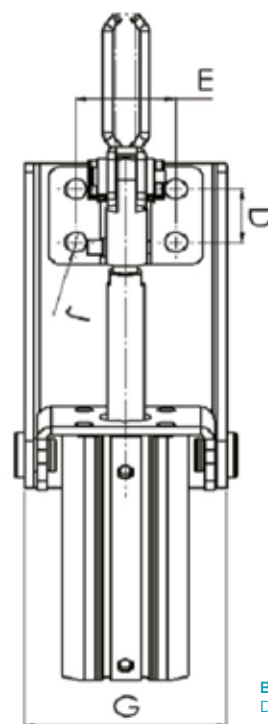

KF-017 DBL P

BASES
D - Dobrada

HASTES
B - Bifurcada
S - Sólida
L - Longa

REFERÊNCIA	FORÇA DE RETENÇÃO KGF	A	B	C	D	E	G	H	J	ROSCA CIL	ÂNGULO DE ABERTURA	PONTEIRA	PESO KG
KF-012 DB P	90	53	235	26	12,7	27	50	42	5,6	1/8" NPT	70	M6	0,630
KF-017 DB P	170	72	238	35	19	32	64	53	7,0	M5	100	M8	1,510
KF-017 DBL P	150	72	268	35	19	32	64	83	7,0	M5	100	M8	1,530
KF-017 DS P	200	72	268	35	19	32	64	83	7,0	M5	100	M8	1,530
KF-011 DB P	280	97	328	47	32	44	79	86	8,5	1/8" NPT	100	M10	2,830
KF-011 DBL P	250	97	354	47	32	44	79	112	8,5	1/8" NPT	100	M10	2,860
KF-011 DS P	300	97	354	47	32	44	79	112	8,5	1/8" NPT	100	M10	2,850
KF-111 DB P	680	119	393	55	32	45	89,5	100	8,5	1/8" NPT	100	M10	4,700
KF-111 DS P	700	119	438	55	32	45	89,5	145	8,5	1/8" NPT	100	M10	4,700
KF-111 DBL P	650	119	393	55	32	45	89,5	145	8,5	1/8 in NPT	100	M10	3,55

GRAMPOS PNEUMÁTICOS

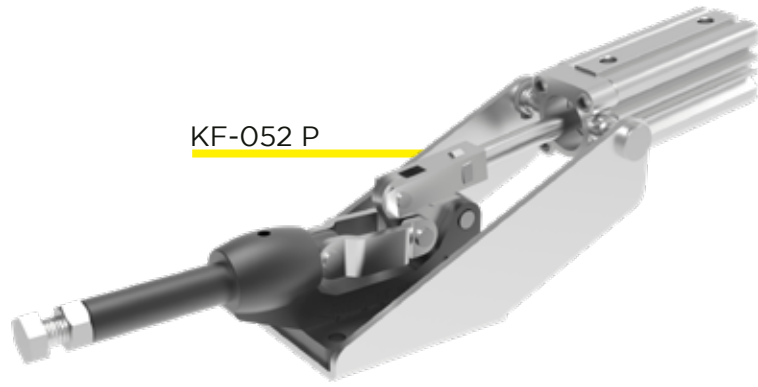

KF-052 P

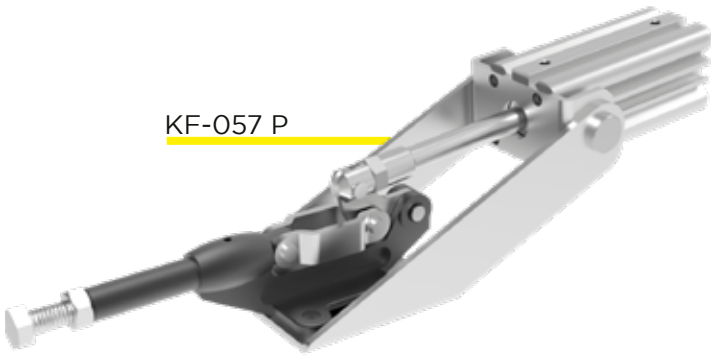
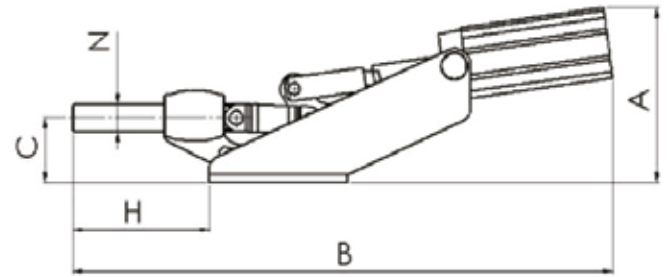

KF-057 P

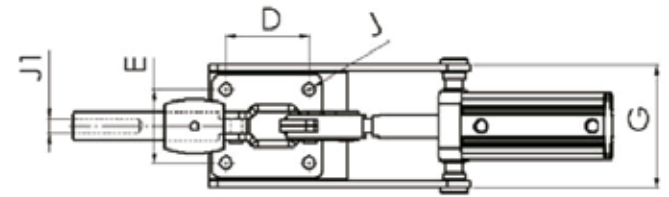

REFERÊNCIA	FORÇA DE RETENÇÃO KGF	A	B	C	D	E	G	H	J	J1	N	ROSCA CIL	PONTEIRA	PESO KG
KF-057 P	230	80	284	25	35	40	65	68	7,0	M8X1,25	12	M5	M12	1,500
KF-052 P	700	119	390	44	60	50	83,5	99	8,5	M12X1,75	19	1/8" NPT	M12	3,700

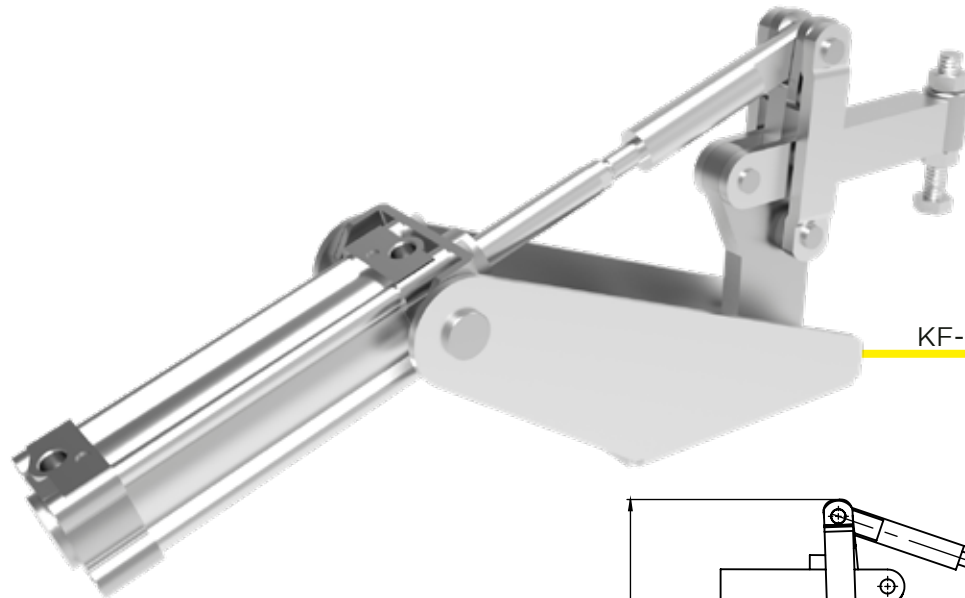

KF-066 TS P

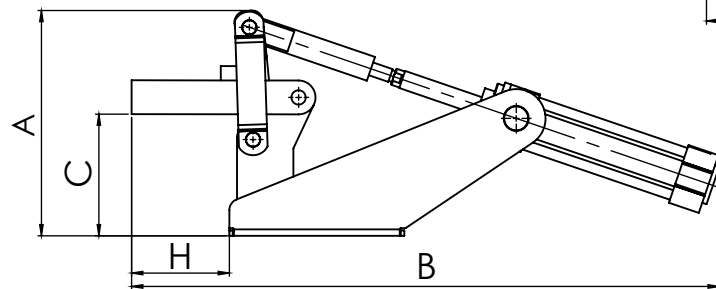
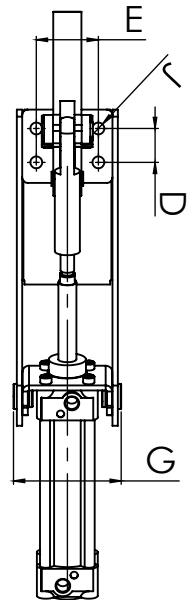

BASES
T - Base T

HASTES
S - Sólida

REFERÊNCIA	FORÇA DE RETENÇÃO KGF	A	B	C	D	E	G	H	J	ROSCA CIL	ÂNGULO DE ABERTURA	PONTEIRA	PESO KG
KF-066 TS P	1400	200	521	108	30	55	95,5	87	10,5	1/8" NPT	55	M12	7,700

GRAMPOS PNEUMÁTICOS

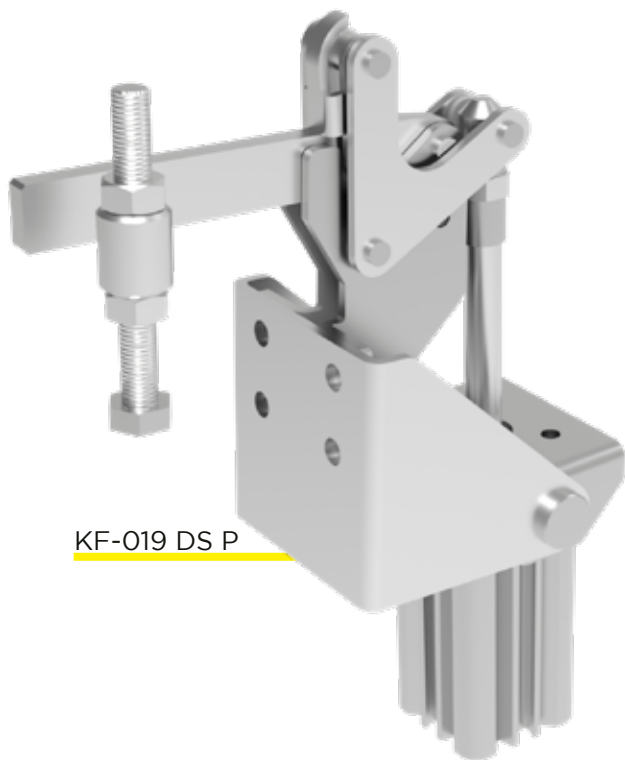

KF-019 DS P

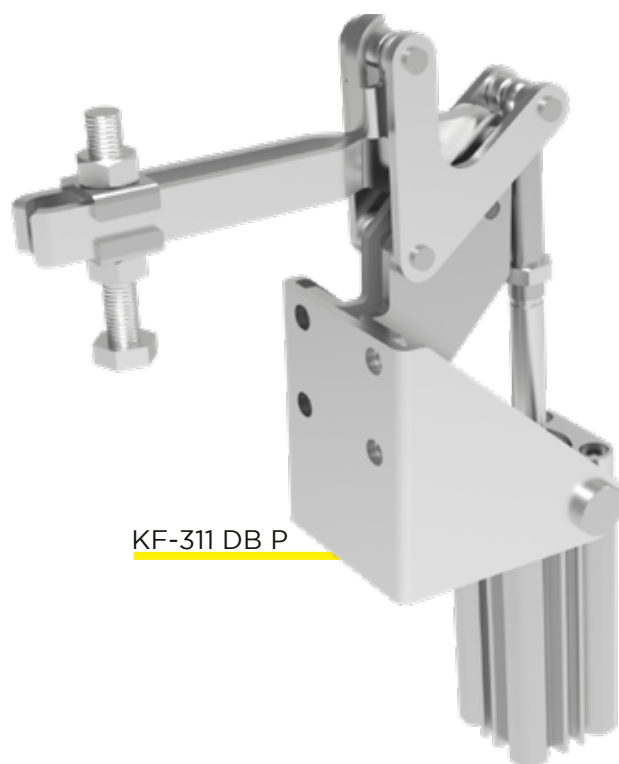

KF-311 DB P

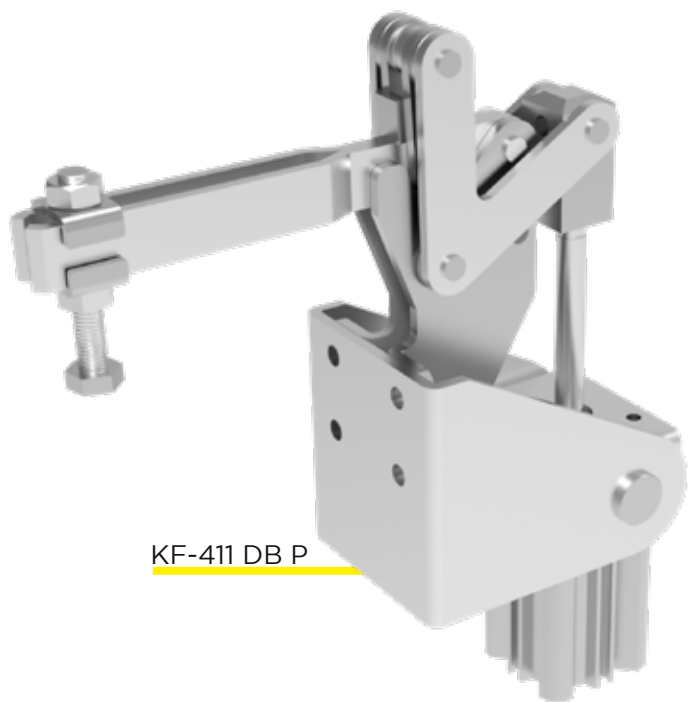

KF-411 DB P

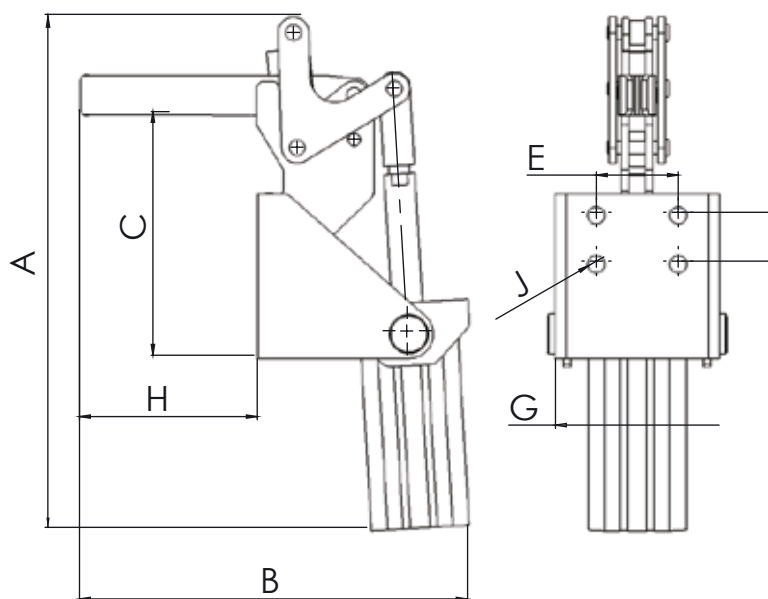

BASES
D - Dobrada

HASTES
B - Bifurcada
S - Sólida

REFERÊNCIA	FORÇA DE RETENÇÃO KGF	A	B	C	D	E	G	H	J	ROSCA CIL	ÂNGULO DE ABERTURA	PONTEIRA	PESO KG
KF-019 DB P	250	210	159	97	20	33,5	67	73	7,0	M5	100	M8	1,600
KF-019 DS P	280	210	159	97	20	33,5	67	73	7,0	M5	100	M8	1,600
KF-311 DB P	250	282	216	130	32	44	75	102	8,5	1/8" NPT	100	M10	2,830
KF-311 DS P	300	282	216	130	32	44	75	102	8,5	1/8" NPT	100	M10	2,800
KF-411 DB P	650	305	260	156	32	45	90	128	8,5	1/8" NPT	100	M10	4,800
KF-411 DS P	700	305	260	156	32	45	90	128	8,5	1/8" NPT	100	M10	4,800

GRAMPOS PNEUMÁTICOS

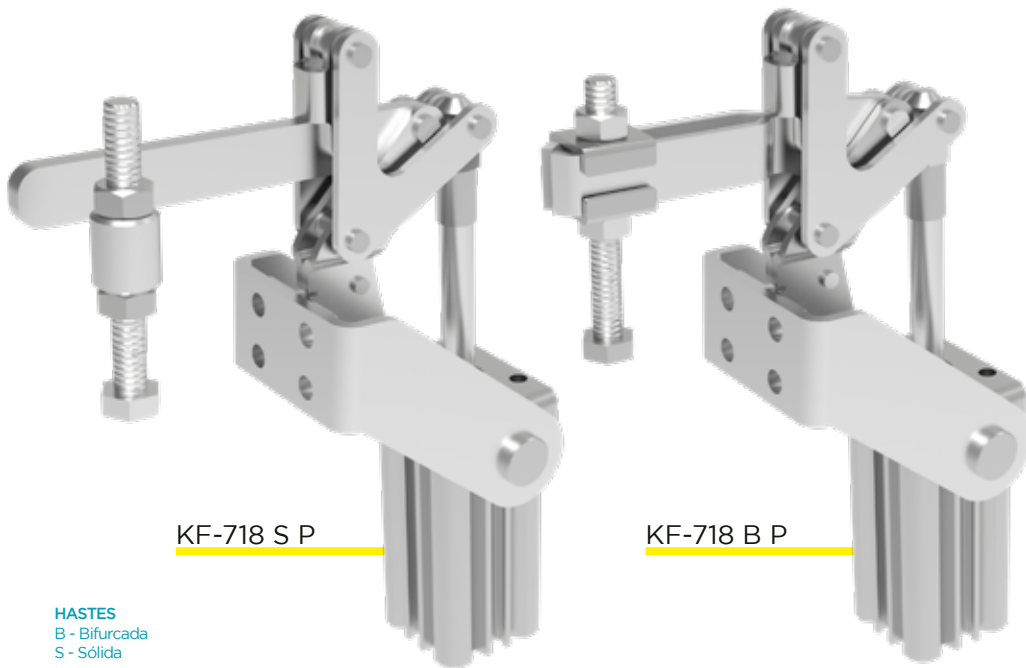

KF-718 S P

KF-718 B P

HASTES
B - Bifurcada
S - Sólida

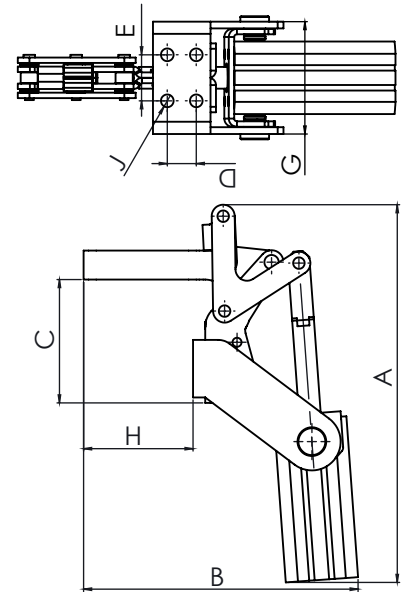

REFERÊNCIA	FORÇA DE RETENÇÃO KGF	A	B	C	D	E	G	H	J	ROSCA CIL	PONTEIRA	PESO KG
KF-718 B P	200	203	152	68	16	25,4	62	60,4	7,0	M5	M8	1,500
KF-718 S P	200	203	169	68	16	25,4	62	78	7,0	M5	M8	1,500

GRAMPOS PNEUMÁTICOS PESADOS

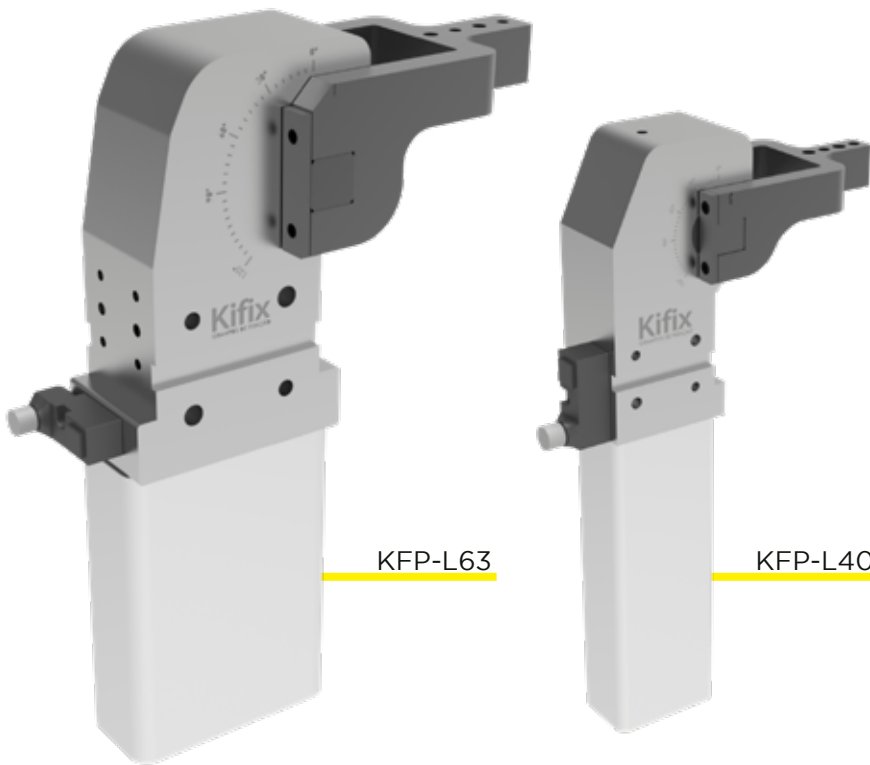

KFP-L63

KFP-L40

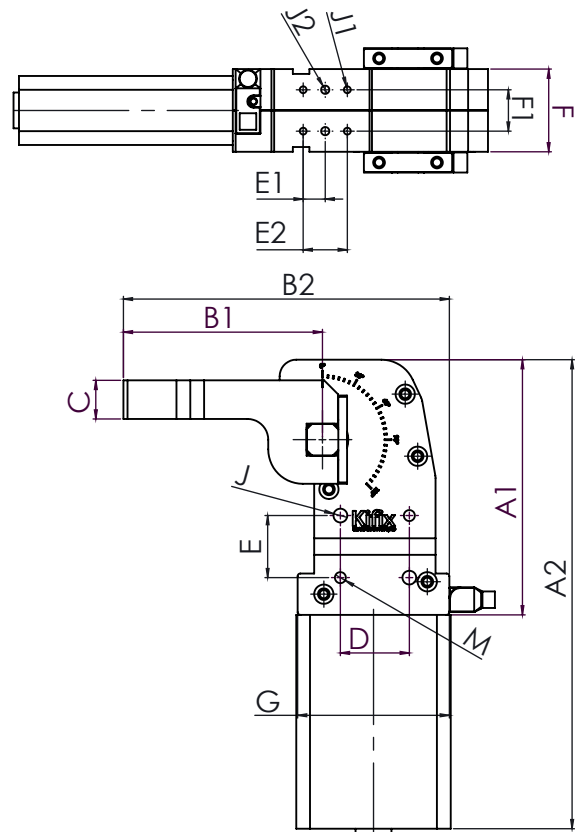

REFERÊNCIA	FORÇA DE RETENÇÃO KGF	ABERTURA (REGULÁVEL)	A1	A2	B1	B2	C	D	D1	E	E1	E2	F	F1	G	J	J1	J2	M	PESO KG
KFP-L40	400	0° - 135°	146	325	110	170	22	35	25	25		20	48	24	65	6	M6		M6	6,000
KFP-L63	1.100	0° - 135°	185	340	144	236	28	50	30	45	16	32	60	30	110	10	M6	6	M10	6,500

DOBRADIÇAS

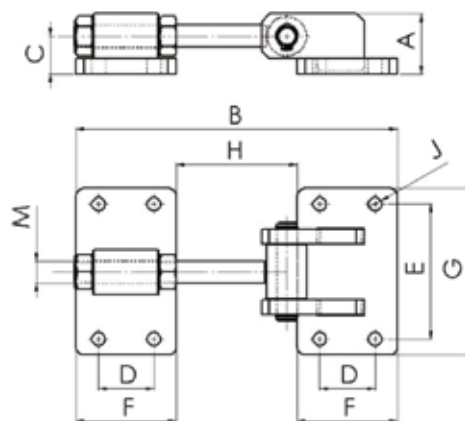
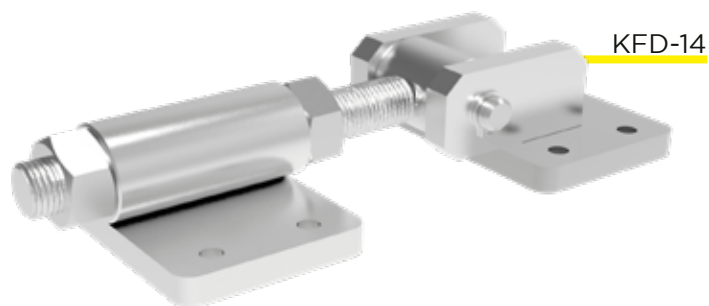

REFERÊNCIA	FORÇA DE RETENÇÃO KGF	A	B	C	D	E	F	G	H	J	M	PESO KG
KFD-14	900	33	156	21	26	60	50	76	56	5,5	M14X2,00	1,040
KFD-19	1400	38,1	203,5	23,8	35	85	63,5	105	76,5	8,5	M14X2,00	1,750

TRINCOS

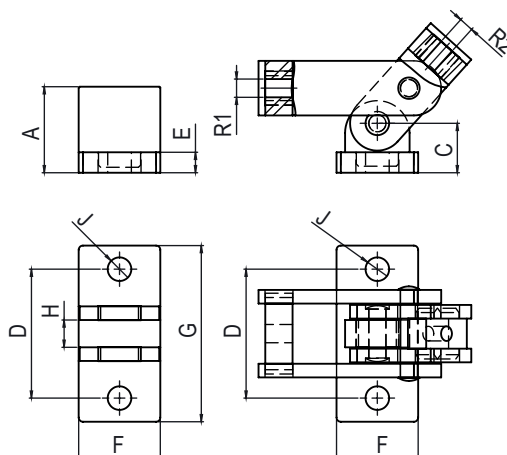
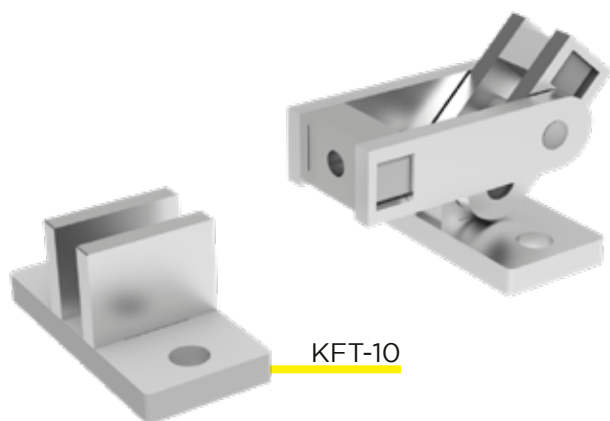

REFERÊNCIA	FORÇA DE RETENÇÃO KGF	A	C	D	E	F	G	H	J	R1	R2	PESO KG
KFT-10	900	40	23	60	9,5	38	82	12,7	11	M10X1,50	M8X1,25	1,040
KFT-14	1400	40	25	70	9,5	38	90	16	12,5	M14X2,00	M14X2,00	1,370

ALICATES

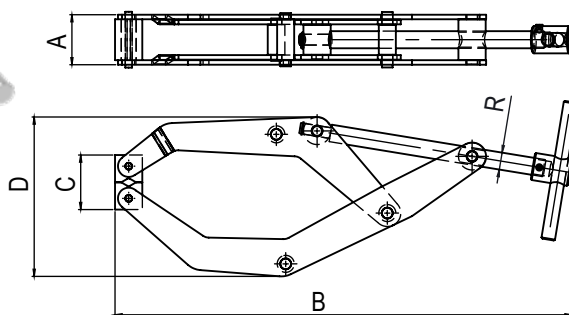
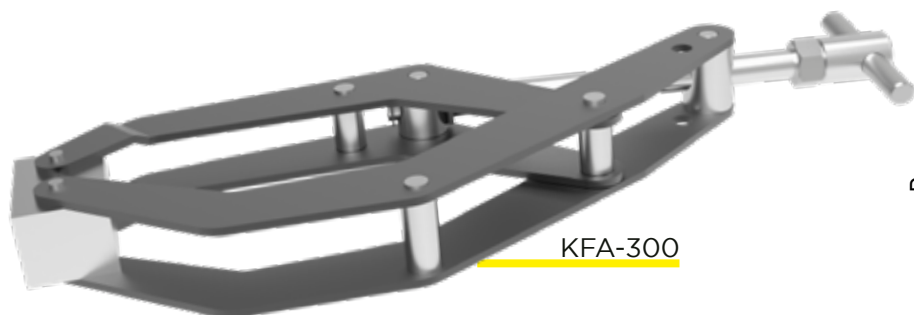

REFERÊNCIA	FORÇA DE RETENÇÃO KGF	A	B	C (FECHADO)	C (ABERTO)	D	ROSCA	PESO KG
KFA-300	150	47	432	60	300	148	M16X2,00	2,750

ALICATES



KFA-25



KFA-35



KFA-45



KFA-70 CA

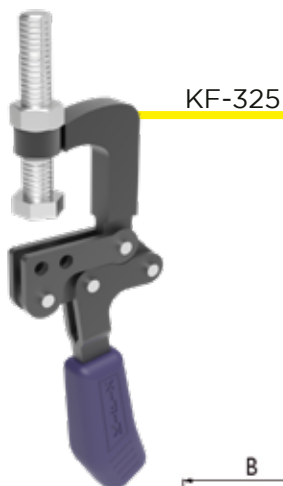

KF-325



KFA-150

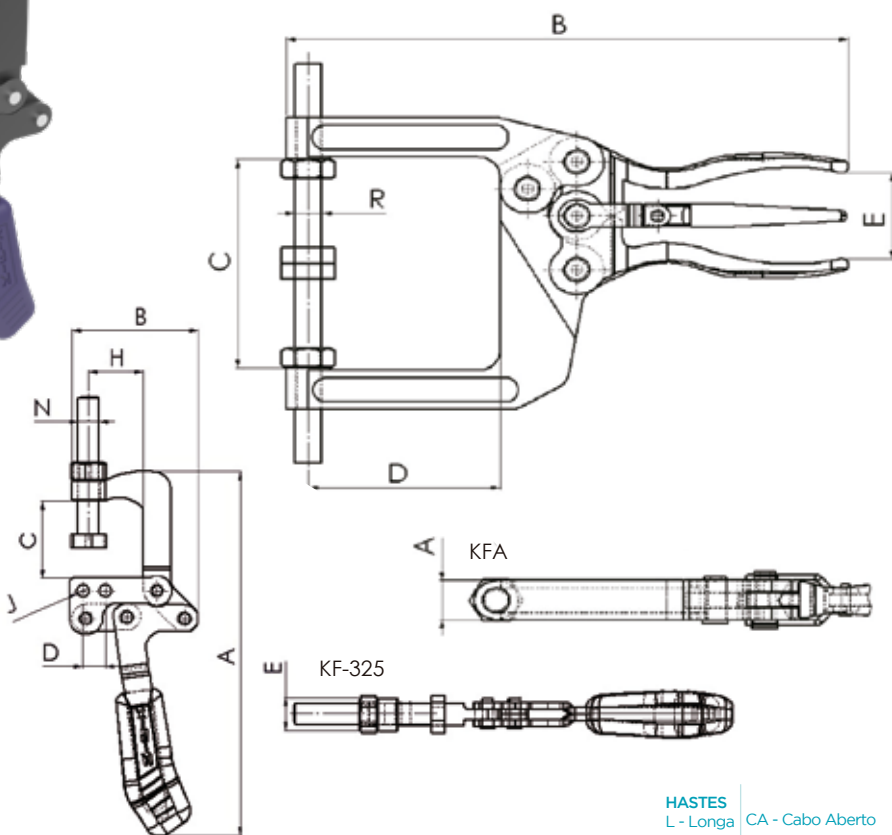

HASTES
L - Longa CA - Cabo Aberto

REFERÊNCIA	FORÇA DE RETENÇÃO KGF	A	B	C	D	E	H	J	N	ÂNGULO DE ABERTURA	PONTEIRA	PESO KG
KF-325	360	212	73	45,3	12,7	19	32	6,800	M12X1,75	93	M12	0,575

REFERÊNCIA	FORÇA DE RETENÇÃO KGF	A	B	C	D	E	ROSCA	PONTEIRA	PESO KG
KFA-25	250	10	140	28	46,5	21,4	M6X1,00	M6	0,240
KFA-35	250	10	140	45	46,5	21,4	M6X1,00	M6	0,250
KFA-45	900	16	205	53	70	35,2	M10X1,50	M10	0,890
KFA-45 CA	900	16	205	53	70	80,2	M10X1,50	M10	1,010
KFA-70	900	16	205	85	70	35,2	M10X1,50	M10	0,980
KFA-70 CA	900	16	205	85	70	80,2	M10X1,50	M10	1,100
KFA-90	900	16	205	93	71,5	35,2	M10X1,50	M10	1,120
KFA-90 CA	900	16	205	93	71,5	80,2	M10X1,50	M10	1,240
KFA-90 L	250	16	305	93	171,5	35,2	M10X1,50	M10	1,490
KFA-100	900	16	205	103	71,5	35,2	M10X1,50	M10	1,150
KFA-100 CA	900	16	205	103	71,5	80,2	M10X1,50	M10	1,270
KFA-150	900	16	205	153	71,5	35,2	M10X1,50	M10	1,290
KFA-150 CA	900	16	205	153	71,5	85,2	M10X1,50	M10	1,410

ALÇA



KF-AL

REFERÊNCIA	A	B	C	D	E	J	PESO KG
KF-AL	174	134	18	26	7,5	6,4	0,460

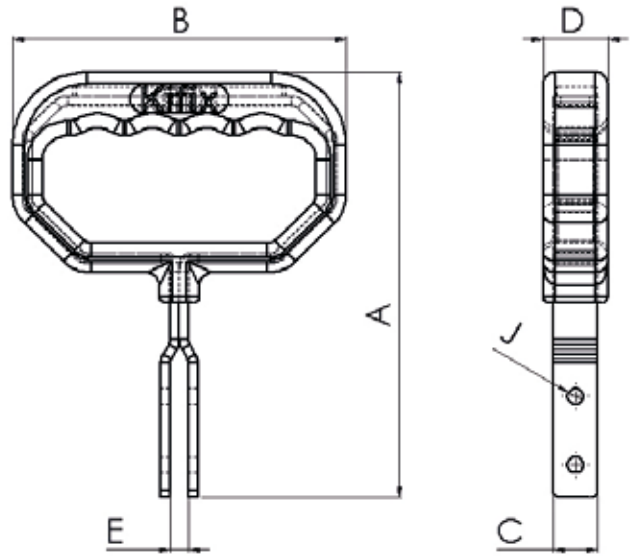

PRODUZIMOS GRAMPOS COM ALÇA
CONFORME A NECESSIDADE DO CLIENTE

PONTEIRAS

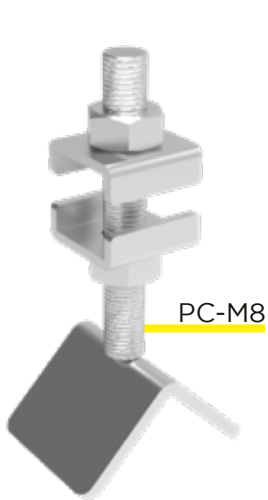

PC-M8

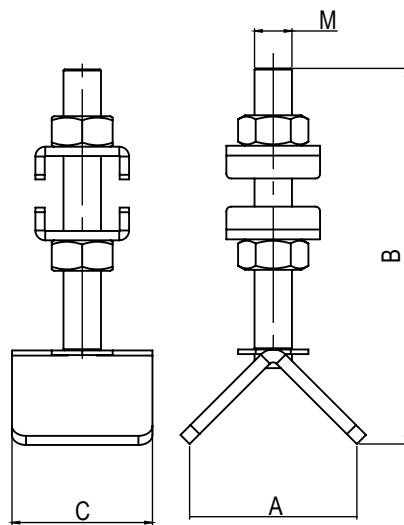

REFERÊNCIA	A	B	C	M
PC-M6	36	80	30	M6
PC-M8	36	100	30	M8
PC-M10	36	91	30	M10
PF-M6 35x40	16	35	40	M6
PF-M6 51x40	16	51	40	M6
PF-M6 51x100	16	51	100	M6
PF-M6 66x100	16	66	100	M6
PF-M8	16	77	100	M8
PF-M10	16	77	100	M10

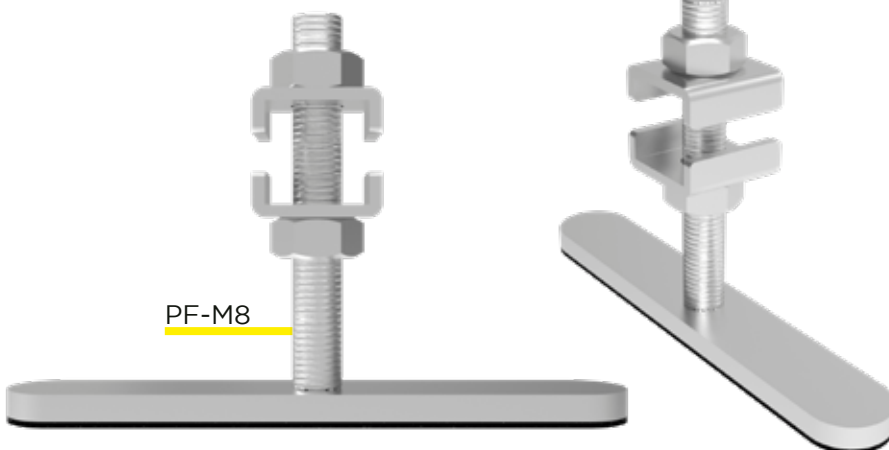

PF-M8

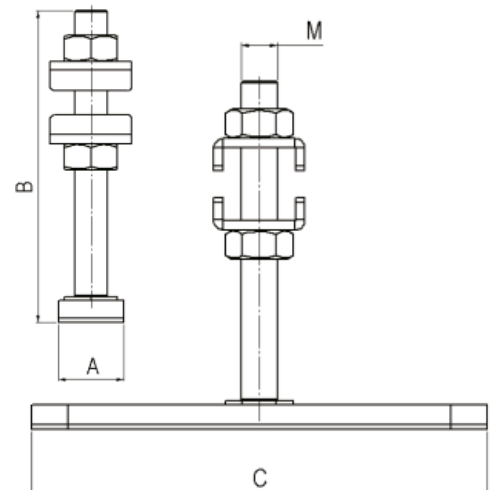

PONTEIRAS

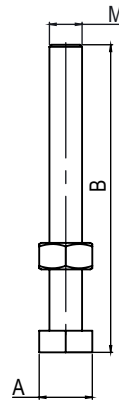
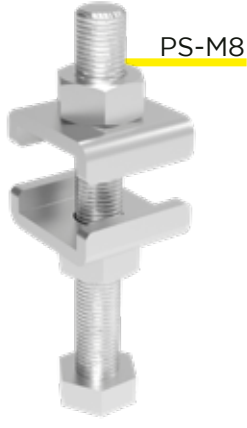

REFERÊNCIA	A	B	M
PP-M6	10	49	M6
PP-M8	13	45	M8
PP-M10	17	51	M10
PP-M12	19	47	M12
PP-M16	24	79	M16
PS-M6	10	64	M6
PS-M8	13	75	M8
PS-M10	17	77	M10
PSB-M6	10	64	M6
PSB-M8	13	75	M8
PSB-M10	17	77	M10
PSB-M12	19	87	M12

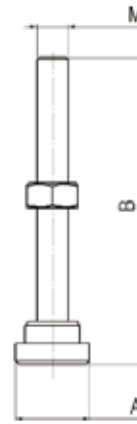
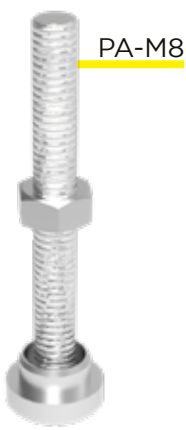

REFERÊNCIA	A	B	M
PA-M6	19	67	M6
PA-M8	19	80	M8
PA-M10	19	80	M10
PA-M12	32	95	M12
PA-M16	32	118	M16
ARP-M6	19	67	M6
ARP-M8	19	80	M8
ARP-M10	19	80	M10
ARB-M6	19	67	M6
ARB-M8	19	80	M8
ARB-M10	19	80	M10
ARB-M16	32	118	M16

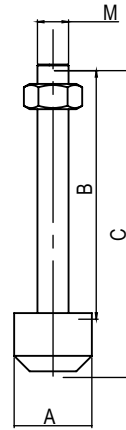

REFERÊNCIA	A	B	C	M
PB-M6	15	57	69	M6
PB-M8	18,5	63	78	M8
PB-M10	23	63	82	M10
BRP-M6	15	57	69	M6
BRP-M8	18,5	63	78	M8
BRP-M10	23	63	82	M10
BRB-M6	15	57	69	M6
BRB-M8	18,5	63	78	M8
BRB-M10	23	63	82	M10
BAP-M6	16	24	31	M6

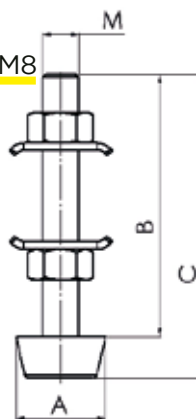
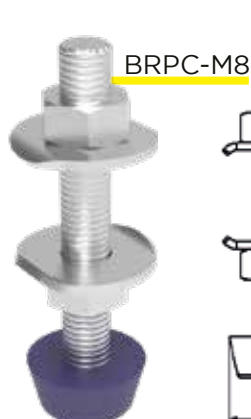
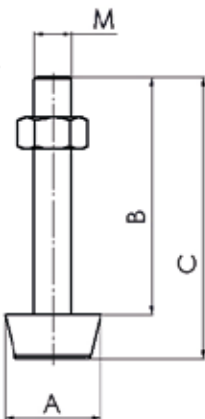

REFERÊNCIA	A	B	C	M
PBC-M4X20	11,2	19	24	M4
PBC-M4X30	11,2	29	34	M4
PBC-M5X25	12,7	25	30	M5
PBC-M5X30	12,7	30	35	M5
PBC-M5X35	12,7	35	40	M5
PBC-M6X30	15,8	29	36	M6
PBC-M6X40	15,8	39	46	M6
PBC-M6X45	15,8	44	51	M6

REFERÊNCIA	A	B	C	M
BRPC-M5X25	12,7	25	30	M5
BRPC-M5X30	12,7	30	35	M5
BRPC-M5X35	12,7	35	40	M5
BRPC-M6X30	15,8	29	36	M6
BRPC-M6X40	15,8	39	46	M6
BRPC-M6X45	15,8	44	51	M6

PONTEIRAS

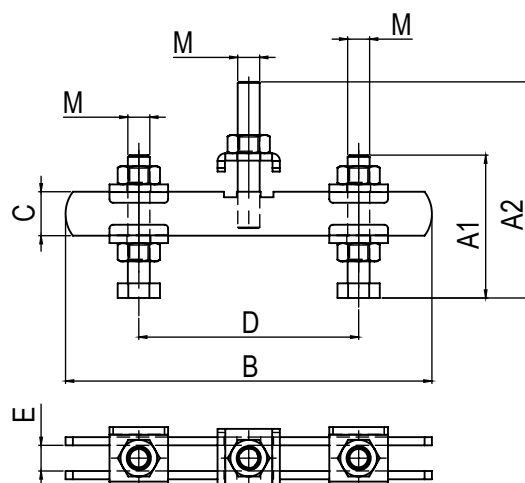
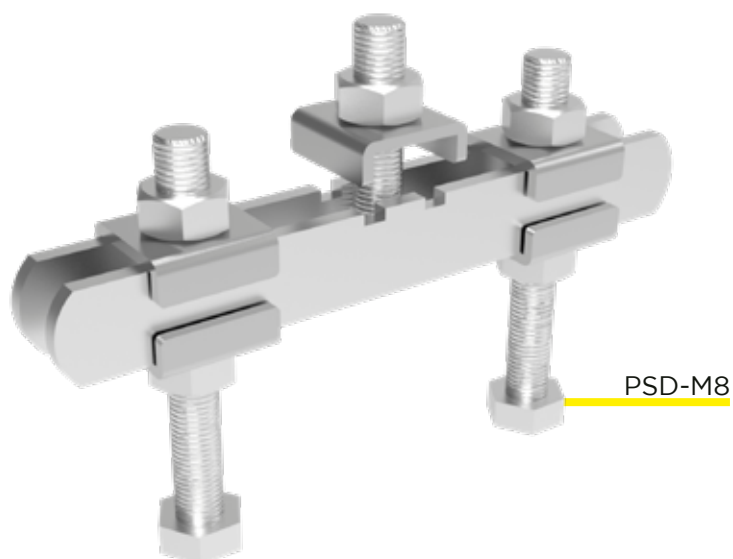

REFERÊNCIA	A1	A2	B	C	D MÍN	D MÁX	E	M
PSD-M6	49	59	100	12	30	80	7	M6
PSD-M8	75	86	120	15	35	92	9	M8
PSD-M10	76	90	180	20	42	148	11	M10

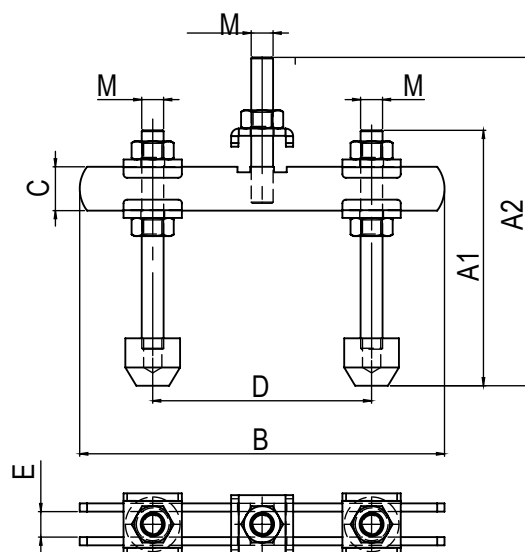
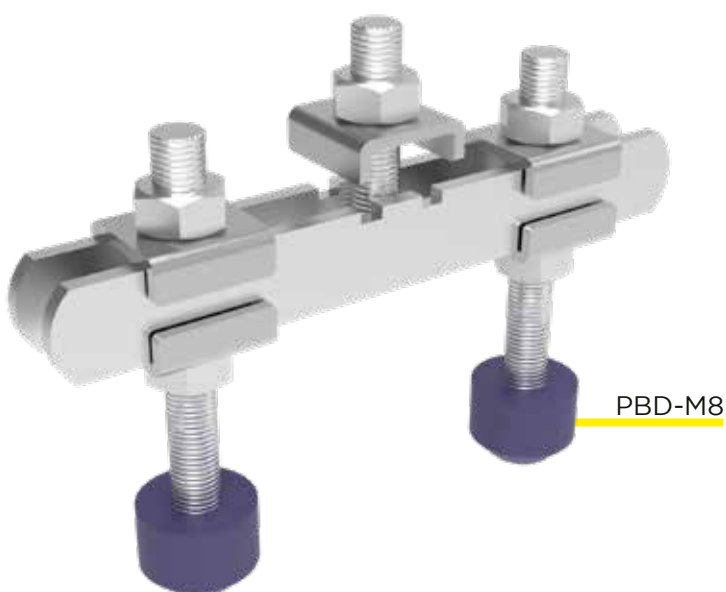

REFERÊNCIA	A1	A2	B	C	D MÍN	D MÁX	E	M
PBD-M6	69	89	100	12	30	80	7	M6
PBD-M8	78	89	120	15	35	92	9	M8
PBD-M10	82	95	180	20	42	148	11	M10

REFERÊNCIA

PP
PS
PSB
PB
BRP
BRB
PBC
BRPC
BAP
PA
ARP
ARB
PC
PF
PBD
PSD

LEGENDA

Ponteira Sextavada com Porca
Ponteira Sextavada com Anilha
Ponteira Sextavada com Bucha
Ponteira Borracha com Porca
Ponteira Borracha com Anilha
Ponteira Borracha com Bucha
Ponteira Borracha Cônica com Porca
Ponteira Borracha Cônica com Anilhas Redondas
Ponteira Borracha Articulada com Porca
Ponteira Articulada com Porca
Ponteira Articulada com Anilha
Ponteira Articulada com Bucha
Ponteira Cantoneira com Anilha
Ponteira Feltro com Anilha
Ponteira Dupla de Borracha
Ponteira Dupla Parafuso Sextavado

BASE ELEVADA

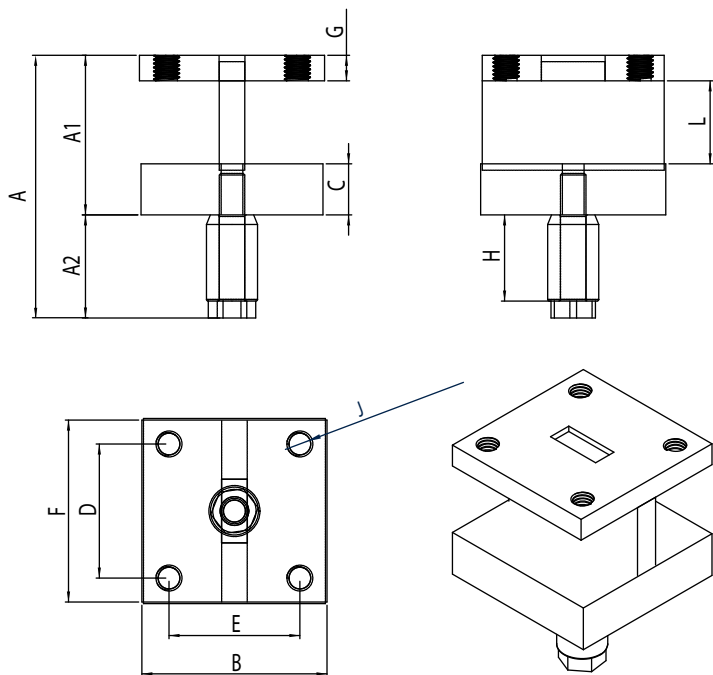

MS BE Ø 22 H50 - KF-532/528

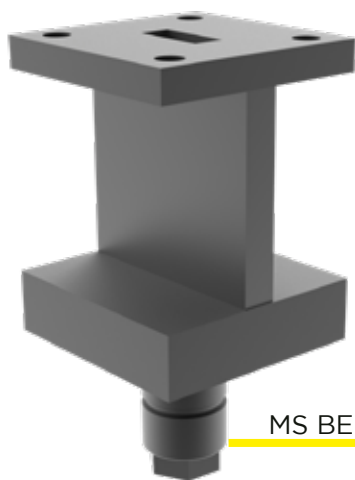

MS BE Ø 22 H75 - KF-532/528

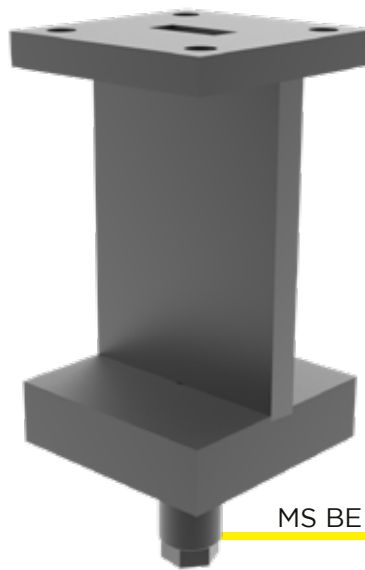

MS BE Ø 22 H50 - KF-532/528

MS - Mesa de solda
BE - Base elevada
H - Altura

REFERÊNCIA	A	A1	A2	B	C	D	E	F	G	H	J	L	PESO KG
MS BE Ø 16 H50 - KF-532/528	82,3	50	32,3	58	16	42	41	57	8	27	M8	26	0,760
MS BE Ø 22 H50 - KF-532/528	88,4	50	36,4	58	16	42	41	57	8	30	M8	26	0,820
MS BE Ø 28 H50 - KF-532/528	95,5	50	42,5	58	16	42	41	57	8	35	M8	26	0,910
MS BE Ø 16 H75 - KF-532/528	107,3	75	32,3	58	16	42	41	57	8	27	M8	51	0,850
MS BE Ø 22 H75 - KF-532/528	111,4	75	36,4	58	16	42	41	57	8	30	M8	51	0,914
MS BE Ø 28 H75 - KF-532/528	117,5	75	42,5	58	16	42	41	57	8	35	M8	51	0,995
MS BE Ø 16 H100 - KF-532/528	132,3	100	32,3	58	16	42	41	57	8	27	M8	78	0,942
MS BE Ø 22 H100 - KF-532/528	136,4	100	36,4	58	16	42	41	57	8	30	M8	78	1,005
MS BE Ø 28 H100 - KF-532/528	145,5	100	42,5	58	16	42	41	57	8	35	M8	78	1,085

BASE FUSO

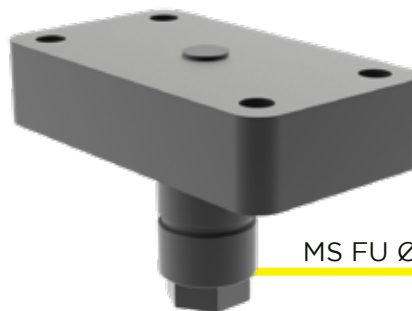
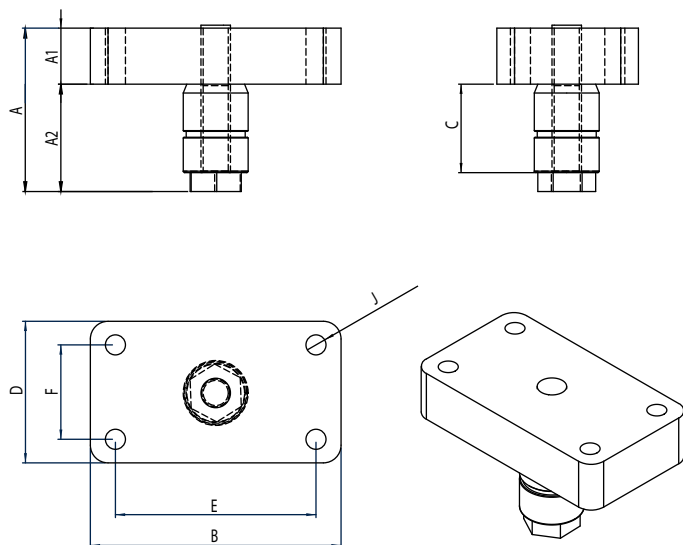

MS FU Ø 22 - KFRL-20

MS - Mesa de solda
FU - Fuso

REFERÊNCIA	A	A1	A2	B	C	D	E	F	J	PESO KG
MS FU Ø 16 - KFRL-20	48,3	16	32,3	85	27	48	68	32	M8	0,542
MS FU Ø 22 - KFRL-20	55,4	19	36,4	85	30	48	68	32	M8	0,695
MS FU Ø 28 - KFRL-20	67,9	25,4	42,5	85	35	48	68	32	M9	0,954

BASE VERTICAL

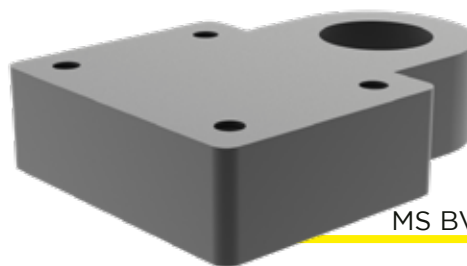
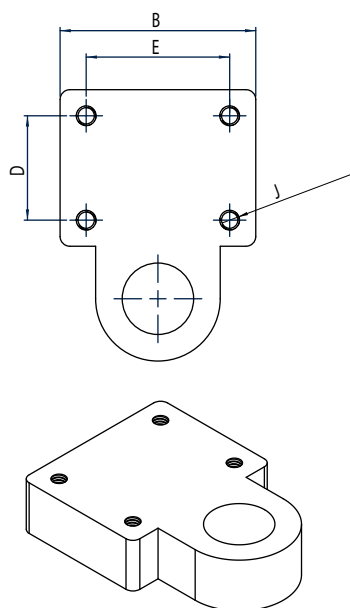

MS BV Ø 22 - KF-011

MS - Mesa de solda
BV - Base vertical

REFERÊNCIA	A	B	C	D	E	J	PESO KG
MS BV Ø 16 - KF-011	83,2	60	16	32	44	M6	0,48
MS BV Ø 22 - KF-011	83,2	60	19	32	44	M6	0,538
MS BV Ø 28 - KF-011	83,2	60	25,4	32	44	M6	0,673
MS BV Ø 16 - KF-111	97,24	67	16	32	45	M8	0,63
MS BV Ø 22 - KF-111	97,24	67	19	32	45	M8	0,72
MS BV Ø 28 - KF-111	97,24	67	25,4	32	45	M8	0,96

BASE HORIZONTAL

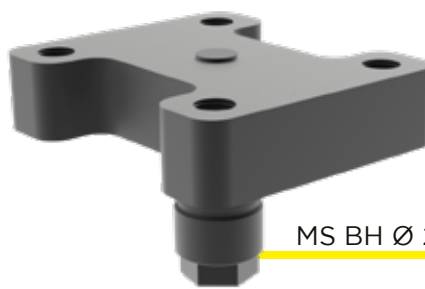
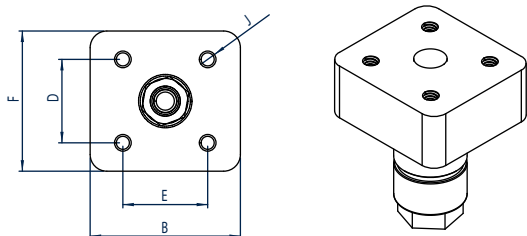
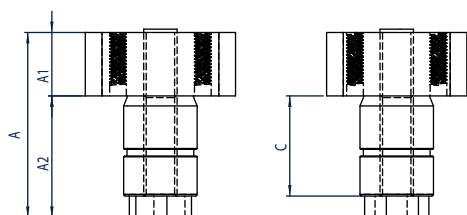
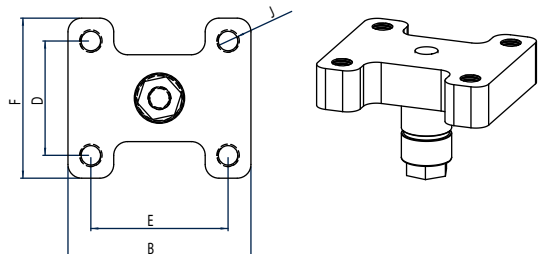
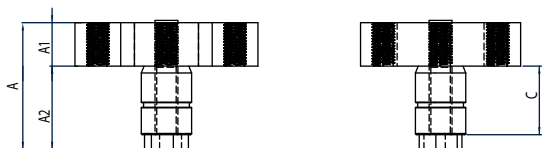

MS BH Ø 22 - KF-052



MS BH Ø 22 - KF-0521

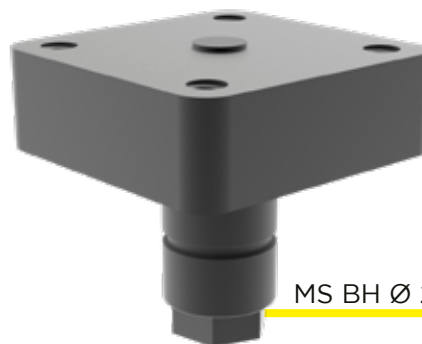

MS BH Ø 22 - KF-532

MS - Mesa de solda
BH - Base horizontal

REFRÊNCIA	A	A1	A2	B	C	D	E	F	J	PESO KG
MS BH Ø 16 - KF-052	48,3	16	32,3	80	27	50	60	70	M10	0,56
MS BH Ø 22 - KF-052	55,4	19	36,4	80	30	50	60	70	M10	0,713
MS BH Ø 28 - KF-052	67,9	25,4	42,5	80	35	50	60	70	M10	0,997
MS BH Ø 16 - KF-057	48,3	16	32,3	50	27	35	40	55	M6	0,316
MS BH Ø 22 - KF-057	55,4	19	36,4	50	30	35	40	55	M6	0,43
MS BH Ø 28 - KF-057	67,9	25,4	42,5	50	35	35	40	55	M6	0,62
MS BH Ø 16 - KF-511	48,3	16	32,3	36	27	24	26	37	M6	0,558
MS BH Ø 22 - KF-511	55,4	19	36,4	36	30	24	26	37	M6	0,296
MS BH Ø 28 - KF-511	67,9	25,4	42,5	36	35	24	26	37	M6	0,44
MS BH Ø 16 - KF-521	48,3	16	32,3	45	27	25,4	24	42	M8	0,278
MS BH Ø 22 - KF-521	55,4	19	36,4	45	30	25,4	24	42	M8	0,38
MS BH Ø 28 - KF-521	67,9	25,4	42,5	45	35	25,4	24	42	M8	0,553
MS BH Ø 16 - KF-531	48,3	16	32,3	50	27	32	37	55	M10	0,363
MS BH Ø 22 - KF-531	55,4	19	36,4	50	30	32	37	55	M10	0,483
MS BH Ø 28 - KF-531	67,9	25,4	42,5	50	35	32	37	55	M10	0,691
MS BH Ø 16 - KF-532	48,3	16	32,3	57	27	41	42	58	M10	0,442
MS BH Ø 22 - KF-532	55,4	19	36,4	57	30	41	42	58	M10	0,577
MS BH Ø 28 - KF-532	67,9	25,4	42,5	57	35	41	42	58	M10	0,817
MS BH Ø 16 - KF-533	48,3	16	32,3	49	27	41	36	50	M8	0,448
MS BH Ø 22 - KF-533	55,4	19	36,4	49	30	41	36	50	M8	0,583
MS BH Ø 28 - KF-533	67,9	25,4	42,5	49	35	41	36	50	M8	0,824

ALICATES

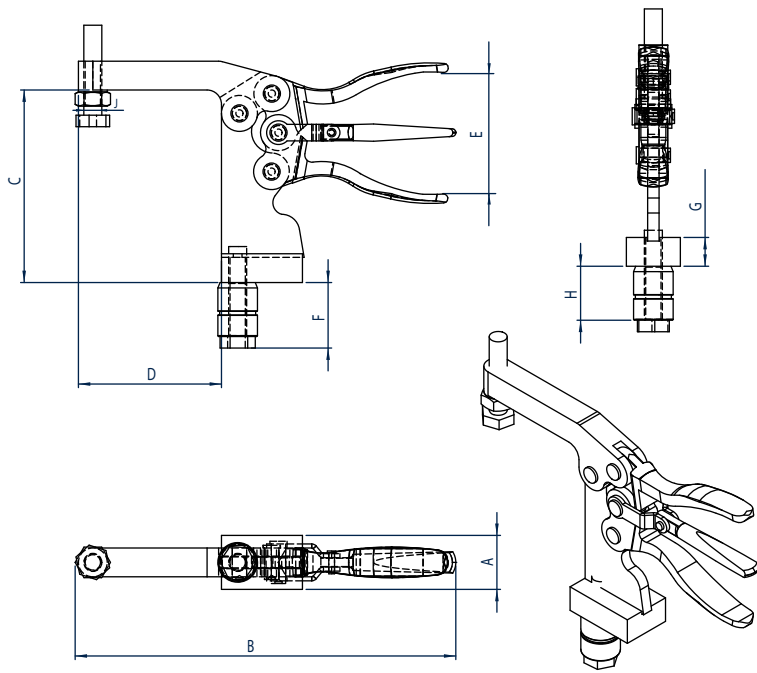

KFA-200 MS Ø 22



MS - Mesa de solda

REFERÊNCIA	A	B	C	D	E	F	G	H	J	PESO KG
KFA-200 MS Ø 16	30	212	107,52	79,5	58	32,3	16	27	M10	0,945
KFA-200 MS Ø 22	30	212	107,52	79,5	58	32,3	16	30	M10	1,007
KFA-200 MS Ø 28	30	212	107,52	79,5	58	32,3	16	35	M10	1,094

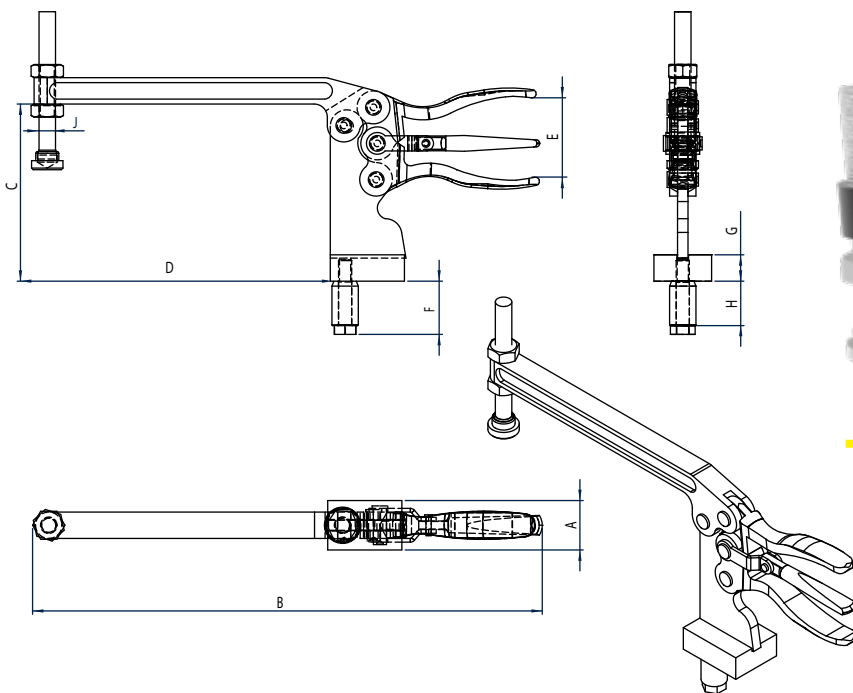

KFA-200 L MS Ø 22



MS - Mesa de solda
L- Haste longa

REFERÊNCIA	A	B	C	D	E	F	G	H	J	PESO KG
KFA-200 L MS Ø 16	30	307	107,52	179,79	58	32,3	16	27	M10	1,129
KFA-200 L MS Ø 22	30	307	107,52	179,79	58	32,3	16	30	M10	1,180
KFA-200 L MS Ø 28	30	307	107,52	179,79	58	32,3	16	35	M10	1,266

GRAMPO SARGENTO



MSSG 120X300 MM

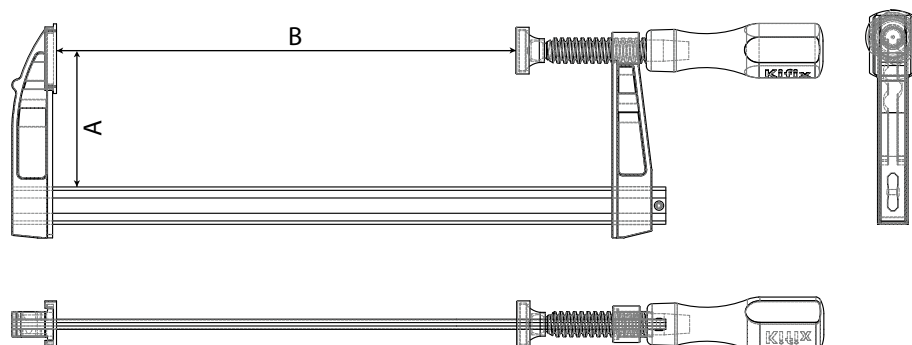
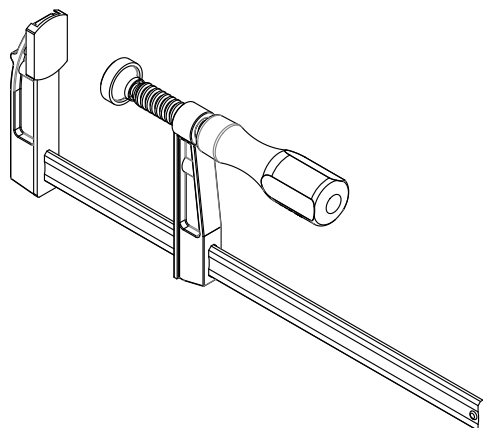

MS - Mesa de solda
SG - Sargento

REFERÊNCIA	FORÇA DE RETENÇÃO KGF	A	B	PESO KG
KFSG 50X100 MM	1700	50	100	0,33
KFSG 50X150 MM	1700	50	150	0,35
KFSG 50X200 MM	1700	50	200	0,38
KFSG 50X300 MM	1700	50	300	0,42
KFSG 80X200 MM	2700	80	200	0,74
KFSG 80X300 MM	2700	80	300	0,93
KFSG 80X400 MM	2700	80	400	1,12
KFSG 80X500 MM	2700	80	500	1,31
KFSG 100X200 MM	3300	100	200	1,08
KFSG 100X400 MM	3300	100	400	1,38
KFSG 100X500 MM	3300	100	500	1,46
KFSG 100X600 MM	3300	100	600	1,58
KFSG 120X250 MM	4500	120	250	1,47
KFSG 120X300 MM	4500	120	300	1,55
KFSG 120X400 MM	4500	120	400	1,70
KFSG 120X500 MM	4500	120	500	1,85
KFSG 120X600 MM	4500	120	600	2,00
KFSG 120X800 MM	4500	120	800	2,29

GRAMPO SARGENTO RÁPIDO

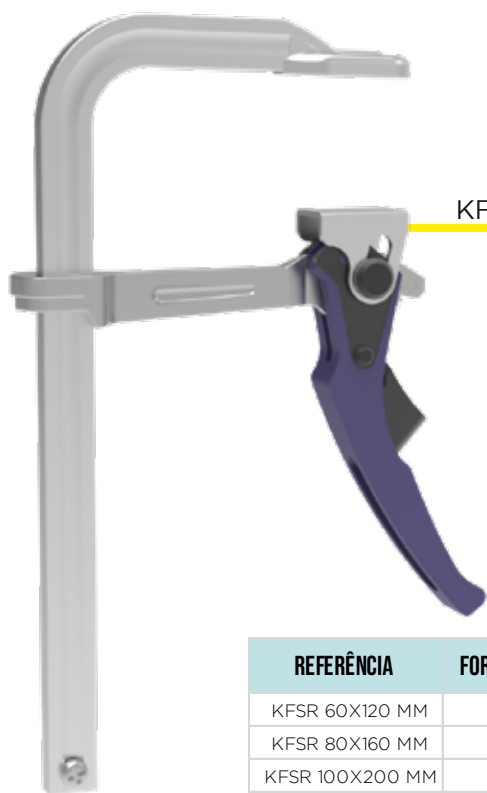

KFSR 120X300 MM

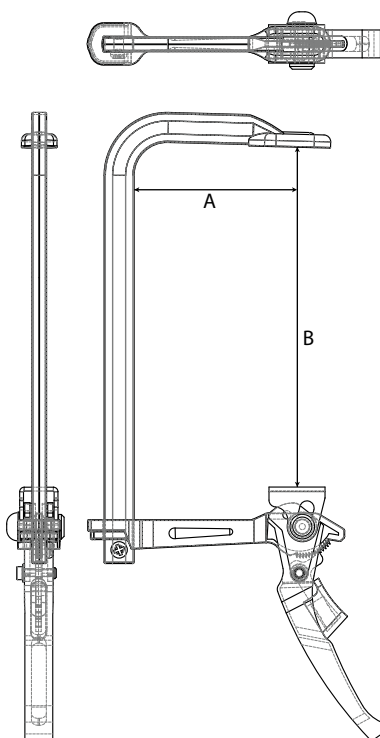
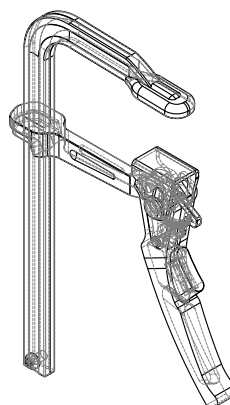

REFERÊNCIA	FORÇA DE RETENÇÃO KGF	A	B	PESO KG
KFSR 60X120 MM	1600	60	120	0,46
KFSR 80X160 MM	1600	80	160	0,57
KFSR 100X200 MM	2100	100	200	1,18
KFSR 100X250 MM	2100	100	250	1,25
KFSR 100X300 MM	2100	100	300	1,38
KFSR 100X400 MM	2100	100	400	1,51
KFSR 120X250 MM	3000	120	250	1,45
KFSR 120X300 MM	3000	120	300	1,53
KFSR 120X400 MM	3700	120	400	2,49
KFSR 120X500 MM	3700	120	500	2,70
KFSR 120X600 MM	3700	120	600	2,91

GRAMPO TIPO C

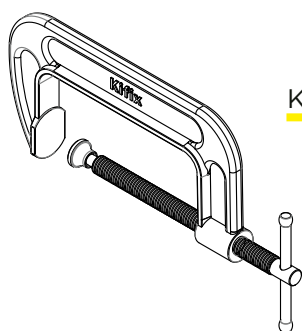

KFSC 3 POL (75 MM)

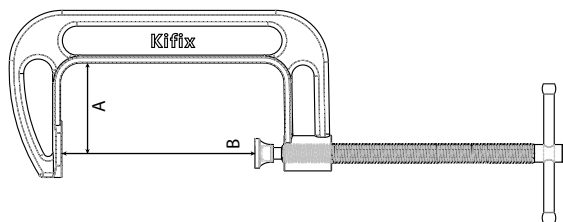

REFERÊNCIA	FORÇA DE RETENÇÃO KGF	A	B	PESO KG
KFSC 1 POL (25MM)	1000	25	25	0,09
KFSC 2 POL (50MM)	2300	26	50	0,175
KFSC 3 POL (75MM)	5500	50	75	0,44
KFSC 4 POL (100MM)	7000	60	100	0,64
KFSC 5 POL (125MM)	7500	67	125	0,95
KFSC 6 POL (150MM)	9000	72	150	1,23
KFSC 8 POL (200MM)	10000	88	200	1,79

Mais de 15 anos de experiência no mercado

• MATÉRIA PRIMA

Realizamos cortes em carbono até 25,4mm e inox até 12mm. Materiais especiais são cortados sob consulta. Dispomos também de um diversificado estoque de matéria prima, agilizando a entrega de acordo com a necessidade do cliente.

SERVIÇO COMPLETO•

Além do corte, oferecemos o serviço de dobra e pintura, entregamos o conjunto completo para você!

• MÁQUINAS DE PONTA

Possuímos duas máquinas de alta performance Trumpf 1030. uma das melhores do mercado. Se beneficie do nosso serviço, entre em contato conosco para cortarmos suas peças.



Contato direto corte a laser:  (54) 99991.2831

Distribuidora oficial da siegmund no Brasil

A Siegmund é uma empresa alemã, líder mundial na fabricação de mesas de solda e sistemas de fixação para solda. A Kifix Tools é a distribuidora nacional com atendimento e entrega para todo o país.



MESAS DE SOLDA 16MM



BASIC 16
PROFESSIONAL 750
EXTREME 8.7
EXTREME 8.7 PLUS

*Imagem representativa da mesa Basic 16



MESAS DE SOLDA 22MM



PROFESSIONAL 750
EXTREME 8.7
EXTREME 8.7 PLUS

*Imagem representativa da mesa Professional 750



MESAS DE SOLDA 28MM



BASIC 28
PROFESSIONAL 750
PROFESSIONAL EXTREME
EXTREME 8.8 PLUS

*Imagem representativa da mesa Basic 28

ACESSÓRIOS



*Exemplos de alguns dos acessórios disponíveis



Contato direto mesas de solda:  (54) 99649.4038



FABRICAMOS &
em Inox &
com trava



Kifix[®]
GRAMPOS DE FIXAÇÃO



APLICAÇÕES GRAMPOS

GRAMPOS DE FIXAÇÃO APERTO RÁPIDO ROBUSTEZ AGILIDADE



ACESSE:



KIFIX INDÚSTRIA E COMÉRCIO LTDA.

Fone/Fax: 54 3028.4614/3028.4615 | kifix@kifix.com.br

Rua Gov. Roberto Silveira, 899 - Santa Catarina

CEP 95032-710 - Caxias do Sul | RS